

ECS servo system

for multi-axis applications



Dynamic, powerful, compact

Lenze

No matter which drive solution you imagine, we make your dreams come true.

True to our slogan (one stop shopping) we offer you a complete program of electronic and mechanical drive systems which is distinguished by reliability and efficiency.

The scope of our program includes frequency inverters, servo controllers, variable-speed drives, speed reduction gearboxes, motors, brakes, clutches, decentralised I/O and operator and display units.



Many well-known companies use Lenze products in various applications.

Overview

ECS servo system and accessories

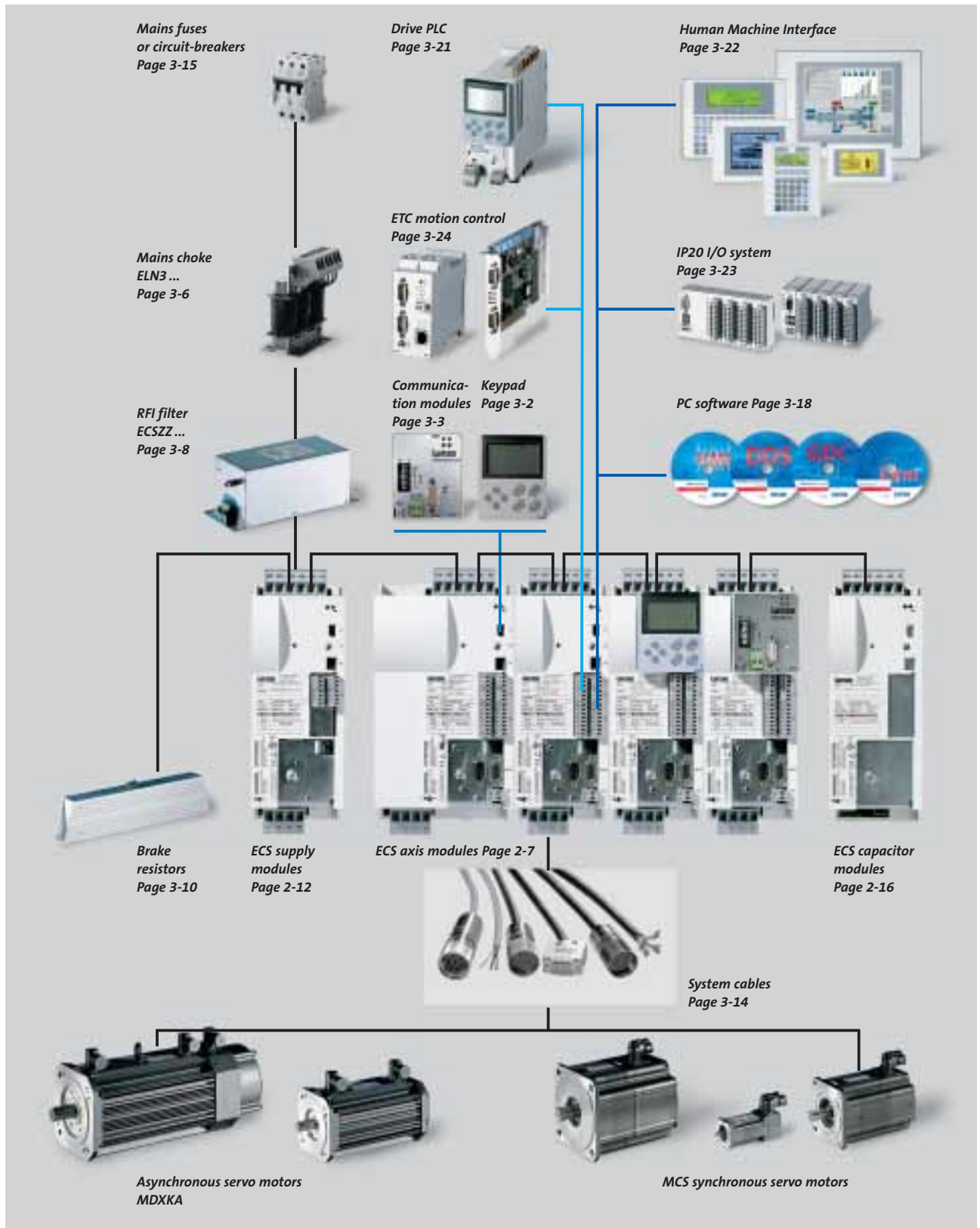

ECS servo system | Dynamic, powerful, compact

Lenze's ECS servo system is the ideal solution wherever high overload capacity for highly dynamic drive tasks is required in conjunction with compact dimensions, fast assembly and problem-free commissioning.

The rugged axis modules, which are supplied with power via the DC bus, provide peak currents up to 64 A. Designs for control cabinet installation, thermal separation (push-through technique), or cold plate mounting support operation in almost any operating conditions. Dedicated software modules ensure optimum adaptation to the required function combined with fast and problem-free commissioning. The "safe standstill" function (EN 954-1, Control Category 3) is a standard component in all axis modules.

Built-in monitoring functions in the central supply modules support a simple and transparent system structure. The high overload capacity optimises the power supply whatever the operating conditions.

Common to all modules are the compact dimensions, fast and well-designed assembly and easy commissioning. An extensive range of system accessories supports tailoring even to specific operating requirements. Two on-board CAN system bus interfaces and a slot for all standard fieldbus systems complete the picture.



*Power supply module
ECSE020
(standard mounting)*



*Axis module
ECSCA008
(cold plate version)*



*Axis module
ECSDA064
(push-through technique)*

Lenze | An introduction

Lenze is the competent partner for your application. Lenze is not only a supplier for single components but also offers solutions for complete drive systems including planning, execution and commissioning.

Furthermore, a worldwide service and distribution network lets you engage a qualified customer advisory service and an after sales service that is fast and extensive.

Our quality assurance system for design, production, sales and service is certified according to DIN ISO 9001 : 2000. Our environmental management system is also certified to DIN EN ISO 14001.

Our customers set the standards for measuring the quality of our products. Our task is to meet your requirements, since customer orientation is a Lenze principle demanding the best quality.

See for yourself.



A worldwide service –
Our team of experts provides reliable and professional assistance.

A true system | Drive and automation technology

Products which are setting the pace in terms of technology and complete drive solutions for machine and system production - just what Lenze is all about. We provide our customers with frequency and servo inverters with powers up to 400 kW. We support both central control cabinet solutions and decentralised drive concepts, e.g. with motor inverters with IP65 type of protection.

Both standard three-phase AC motors and synchronous and asynchronous servo motors are available to complement the various controllers, all of which can be combined with various types of gearboxes. Human Machine Interfaces, decentralised I/O systems and modules for fieldbus interfacing are also available for exchanging information.

Lenze boasts extensive application know-how in all manner of industries. This knowledge has been applied in the design of the controller and PC software, providing an efficient means of implementing numerous standard applications using simple parameter settings.

An all-round service comprising component selection advice, training, commissioning support and even a helpline which can be accessed all over the world and independent system engineering completes the offer.

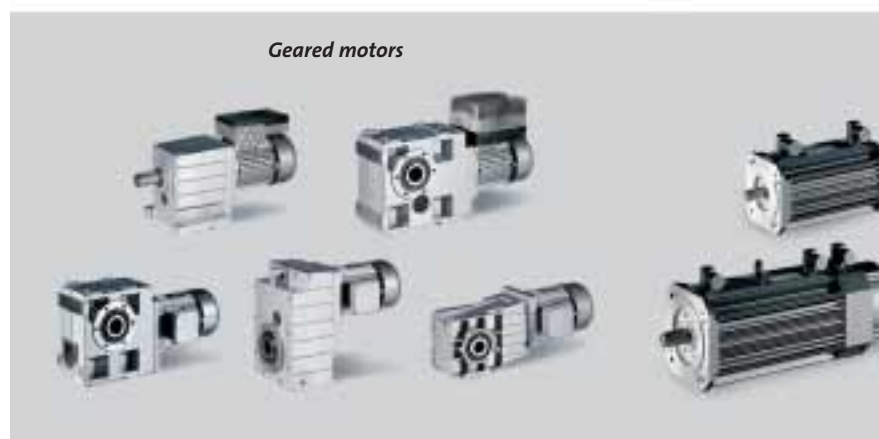

9300 servo inverter



ECS servo system for multi-axis application



Communication modules



9300 vector frequency inverter



8200 vector frequency inverter



8200 motec motor inverter



starttec motor starter



PC software



Software packages



Servo motors



Small drives



Brakes and clutches



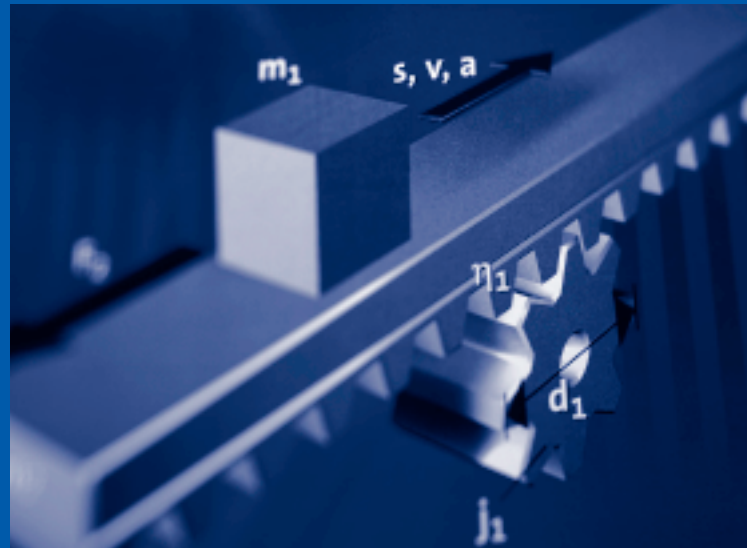

Contents | ECS servo system

General _____ 1-1 **1**

Product information _____ 2-1 **2**

System accessories _____ 3-1 **3**

Dimensioning information _____ 4-1 **4**

Services _____ 5-1 **5**



General | ECS servo system

List of abbreviations

1-3

A step-by-step guide to selecting your system

1-4



1

Controller

U_{mains}	[V]	Mains voltage
I_{mains}	[A]	Mains current
U_{DC}	[V]	DC-bus voltage
U_{k}	[V]	Short circuit voltage
I_{r}	[A]	Rated current/Output current
I_{max}	[A]	Maximum output current
I_{Amax}	[A]	Maximum acceleration current
I_{Orms}	[A]	Standstill current (rms value)
P_{r}	[kW]	Rated power
S_{r}	[kVA]	Output power, inverter
P_{V}	[W]	Power loss, inverter
P_{brake}	[kW]	Maximum braking power
f_{ch}	[kHz]	Switching frequency
f_{max}	[Hz]	Set maximum frequency
f_{d}	[Hz]	Field frequency
L	[mH]	Inductance
n_{r}	[min ⁻¹]	Rated speed
R	[Ω]	Resistance
R_{th}	[k/W]	Thermal resistance
k_{c}	[μF/kW]	Capacity factor

General

ECS□A	Servo axis module
ECS□E	Supply module
ECS□K	Capacitor module
AIF	Application interface (can be plugged into ECS modules)
AC	Alternating current/voltage
DC	Direct current/voltage
DIN	Deutsches Institut für Normung
EMC	Electromagnetic compatibility
EN	European standard
IEC	International Electrotechnical Commission
IP	International Protection Code
NEMA	National Electrical Manufacturers Association
VDE	Verband deutscher Elektrotechniker
CE	Communauté Européenne
IM	International Mounting Code
UL	Underwriters Laboratory Listed Product
UR	Underwriters Laboratory Recognized Product

This section contains a brief description of the essential steps required to select an ECS servo system for your application. Once you have the general system selected, you can then use this catalog to identify and order the required

components. Should you require any assistance selecting your system, please contact your local Lenze sales representative, who will be delighted to help.

Step 1

Calculation of the motor power required for each axis

The maximum torque required for this axis (M_{max}), the maximum speed (n_{max}), the effective torque (M_{rms}) and, if applicable, the transmission ratio i must be calculated for

this purpose. (The Lenze formula collection ID no. 473 731 provides more detailed information about dimensioning drives correctly.)

Gearbox ratio:

- ▶ for optimum dynamics

$$i = \sqrt{\frac{J_{load}}{J_{mot}}}$$

- ▶ for excellent utilisation in continuous operation

$$i = \frac{n_r}{n_{load}}$$

Effective torque:

(for steps with constant torque characteristics)

$$M_{rms} = \sqrt{\frac{1}{t} \sum M_i^2 t_i}$$

Maximum torque:

$$M_{max} = M_{accel} + \frac{1}{i} \frac{1}{n_{gearbox}} M_{load}$$

$$M_{accel} = 2 \cdot \pi \frac{\Delta n}{\Delta t} \left(J_{mot} + \frac{1}{i^2} J_{load} \right)$$

Step 2

Selection of suitable motors

Please see the "MCS Synchronous Servo Motors" and "Global Drive Servo Motors MDXK/MDFQA" catalogs for more detailed information about selecting suitable Lenze servo motors.

Select the motor according to n_{max} , $M_r > M_{rms}$, for highly dynamic applications, you should also take M_{max} and M_0 into account in addition to the following points:

- | | | |
|---|---|-------------------------------------|
| ▶ No air flow permissible in the process | → | Motor without fan MCS, MCA |
| ▶ Fluff or similar which may block the air ducts | → | Motor without fan MCS, MCA |
| ▶ High type of protection required | → | Motor without fan MCS, MCA |
| ▶ High dynamics required | → | Synchronous motor without fan MCS |
| ▶ Operation at constant power at high speeds (field weakening mode) | → | Asynchronous servo motor MDXKA, MCA |
| ▶ Very high power density | → | Synchronous servo motor MCS |
| ▶ Parallel operation of servo motors | → | Asynchronous servo motor MDXKA, MCA |

It is also at this point that you need to specify the appropriate encoder system for your application. Resolvers, SinCos single-turn and multi-turn encoders as well as incremental encoders can be provided to suit your application require-

ments and selected motor types. Please see the "MCS Synchronous Servo Motors" and "Global Drive Servo Motors MDXK/MDFQA" catalogs for more detailed selection information about the various encoder systems.

Step 3

Select the appropriate ECS axis modules

The axis modules are selected on the basis of the maximum currents required (I_{max}), the average power required (P_{rms}) and, if applicable, the holding currents required (I_0).

(Please see the "Global Drive Servo Motors" catalog for the required motor data. The selection tables for ECS axis modules appear on page 2-5 of this catalog.)

Step 4

Select the required ECS supply module

The best way to select the ideal ECS supply module for a multi-axis application is to use a time/power diagram for a complete machine cycle for all axes. The total power characteristic can be calculated by adding the time-based individual axis power ratings and used as the basis for selecting the most suitable ECS supply module. This calculation can also be used to check whether the dimensions of the inter-

nal brake resistor built into the supply module are sufficient for the total braking power which may be required or if an external resistor with a higher rating will be needed. Information about brake resistors appears on page 3-9.

Time/power diagram of a multi-axis servo system

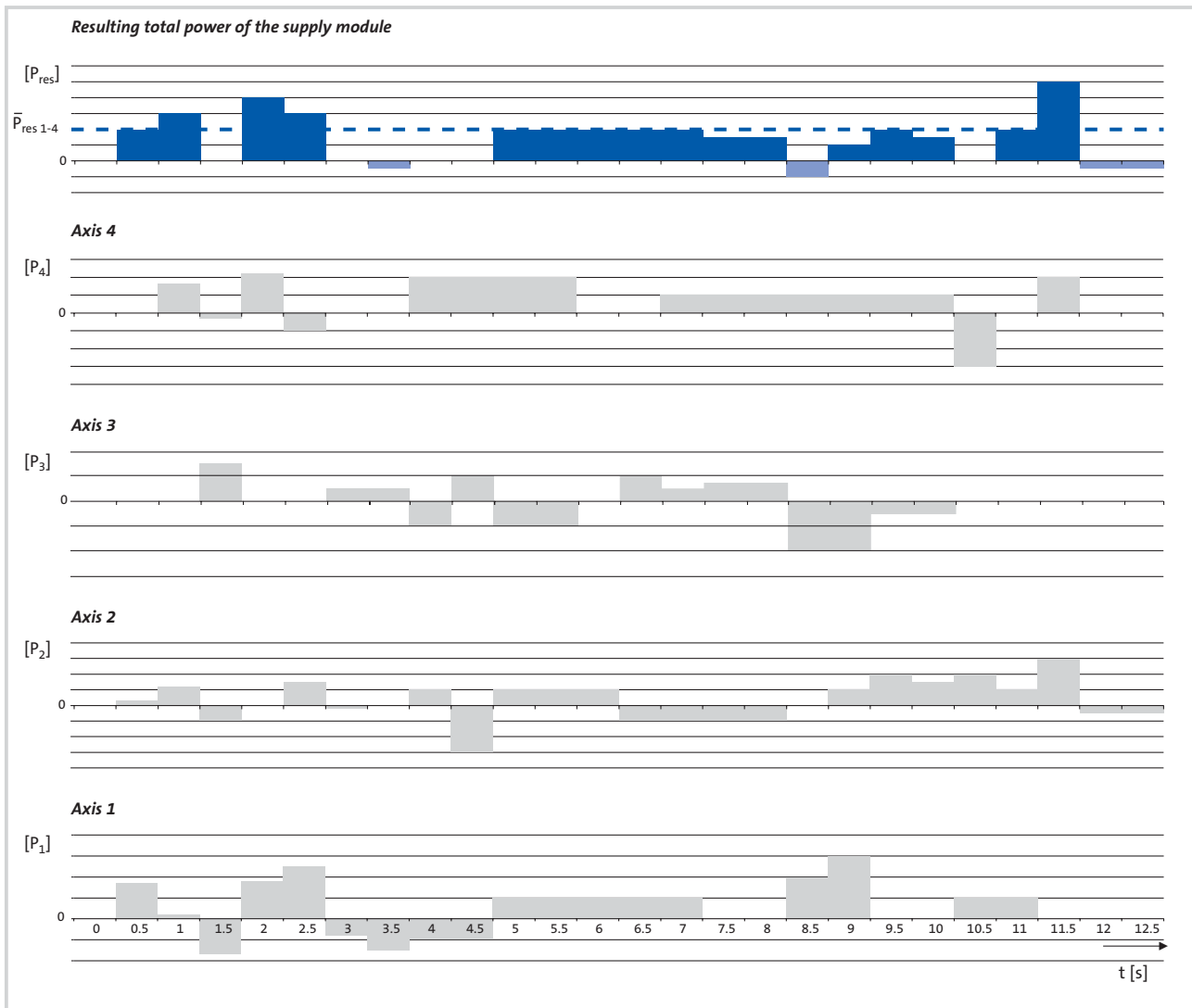

Step 5

Specifying the installation methods for axis and supply modules

ECS servo system axis and supply modules are available in three different versions:

- ▶ As built-in units for fixing to an appropriate mounting plate in the control cabinet
- ▶ In a push-through technique (thermal separation) design, in which the heatsink is plugged into the modules via the backplane of the control cabinet or other assembly space so that the heat loss is dissipated directly outwards, significantly reducing the heat rise inside the control cabinet.

Tip: 1.) It may be possible to select a smaller control cabinet 2.) Less cooling power may be required in the control cabinet.

- ▶ As a cold plate unit. In this version, the ECS modules do not have their own heatsinks but are mounted directly on an existing heatsink in the customer system via the rear-side mounting plate. (It is absolutely essential to take the necessary values for heat transmission and dissipation resistances into account, see page 2-21). If the cold plate method is used, please also note that the ECS supply module does not have a built-in brake resistor. If a brake resistor is required, it must be provided externally (page 3-9).

Step 6

Selection of accessories on the supply side

The following accessories can be selected according to local requirements:

- ▶ Circuit-breakers (see page 3-15)
- ▶ RFI filters (if required) (see page 3-8)
- ▶ Mains chokes (the use of a choke on the mains side is always recommended to reduce the mains r.m.s. current and the stress applied to the DC-bus capacitors. Please take the voltage drop in the DC-bus voltage into account.) (see page 3-6).

Note: DC-bus fuses do not need to be used on the ECS servo system.

Step 7

Selection of additional accessories for control or communication

Lenze offers a wide range of accessories to complete your overall system:

- ▶ Motor and encoder system cables (see "MCS Synchronous Servo Motors" and "Global Drive Servo Motors MDXK/MDFQA" catalogs)
- ▶ Pluggable modules for local operation (page 3-2) and/or connection to a fieldbus (page 3-3)
- ▶ ECSZ□ connector sets for power and control connections (page 3-16)
- ▶ ECSZS shield assembly sets for the EMC-compliant and safe connection of cable shields
- ▶ Text or graphic human machine interfaces, connectable via system bus (page 3-22)
- ▶ Decentralised I/O modules, connectable via system bus (page 3-23)
- ▶ Software for parameter setting and monitoring (page 3-18)
- ▶ ETC Motion Control controller for co-ordinated multi-axis synchronisation (page 3-24)





ECS product information

Features of the system	2-2
Operating conditions/General data	2-4
Overview of module selection	2-5

Axis modules

Features	2-7
Rated data	2-8
Control connections	2-9
Characteristics for maximum output currents	2-10
Type codes for ECS □A axis modules	2-11

Supply modules

Features	2-12
Rated data	2-13
Control connections	2-14
Type codes for ECS□E supply modules	2-15

Capacitor modules

Features	2-16
Rated data	2-17
Connections for ECS□K capacitor modules	2-17

Mechanical dimensions

ECS E□ built-in unit	2-18
ECS D□, push-through technique (with thermal separation)	2-19
ECS D□, cold plate design	2-20
Requirements of external coolers for cold plate design	2-21

Application software

	2-22
--	------

ECS product information

Features of the system

The ECS servo system comprises DC-supplied servo modules capable of overloads up to several hundred percent which have been designed specifically for multi-axis applications with high dynamics and drive performance.

The ECS servo system's functions are designed for use with central control concepts. The distribution of intelligence between the control system and servo modules can be optimised for specific applications. A high degree of

precision is achieved when carrying out multi-axis coordinated movements by transferring synchronised speed and torque setpoints via the integrated CAN motion bus at cycle times below 1 ms. The ECS servo system is therefore ideal for gantry systems, robots, packaging machines or feeding and removal devices in industrial handling.

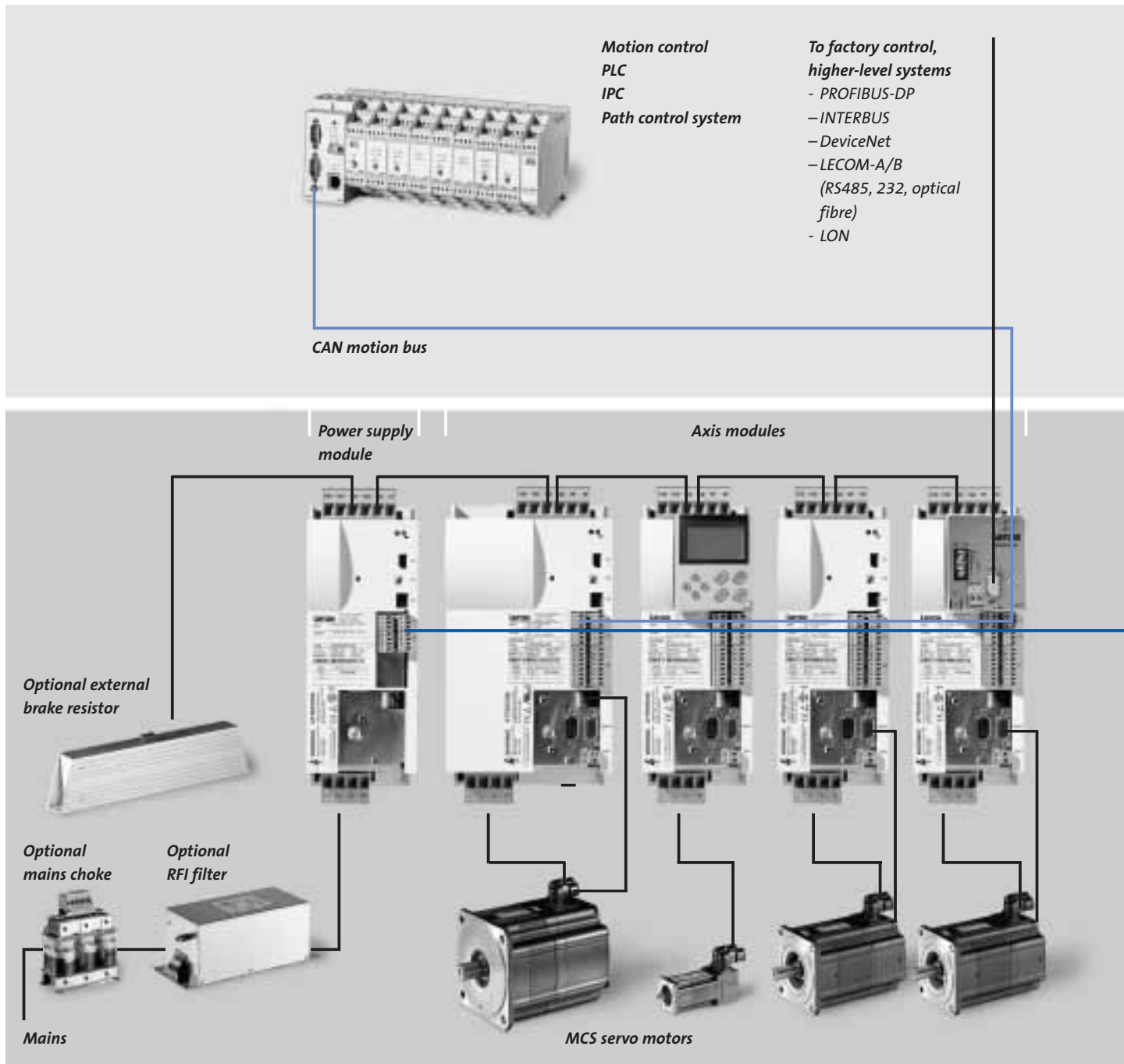

The advantages of the ECS servo system

High dynamics

- ▶ 200% to 300% overload of axis modules
- ▶ Dynamic energy exchange via DC-bus connection

Wide power range

- ▶ $P_r = 1.1 \dots 13.8 \text{ kW}$
- ▶ $I_{\max} = 4.0 \dots 64 \text{ A}$

Central supply modules

- ▶ Minimum cabling
- ▶ Reduced expenditure on switching and fuse elements on the supply side
- ▶ Built-in mains and DC-bus monitoring function
- ▶ Central interference suppression

Couldn't be easier to assemble

- ▶ Pluggable, polarised connection system for power and control terminals, accessible from the front
- ▶ Suitable for wall mounting, push-through technique (thermal separation) or cold plate technique

Little space required

- ▶ Compact design
- ▶ No DC-bus fuses required

Flexible configuration for adaptation to motion control

- ▶ Setpoint selection and actual value feedback via bus

Full network capabilities

- ▶ 2 CAN interfaces as standard in the axis module
- ▶ All popular fieldbus systems are available as optional additional pluggable communication modules

“Safe standstill” acc. to EN 954-1 Control Category 3

UL-approved (File No. E132659), CE-compliant

Built-in motor brake control

- ▶ Internal functions minimise external expenditure
- ▶ Built-in monitoring functions for brake circuit

Can be combined with synchronous and asynchronous motors

- ▶ Resolver or encoder as feedback system (TTL, SinCos, SinCos absolute value)

Optimum matching to MCS range of highly dynamic motors

Operating and service tools



HMI

CAN system bus



Decentralised I/O system

Standards and operating conditions

Conformity	CE	Low-Voltage Directive (73/23/EEC)
Approvals	UL508C	Underwriter Laboratories (File No. E132659) Power conversion equipment
Max. permissible motor cable length	shielded	50 m
Vibration resistance		At mains rated voltage and switching frequency 8 kHz
Climatic conditions		Accelerational stability up to 0.7 g (Germanischer Lloyd, general conditions)
Degree of pollution		Class 3K3 to EN 50178 (no condensation, average relative humidity 30 ... 95%)
Packaging (DIN 4180)		VDE 0110 Part 2 Degree of pollution 2
Permissible temperature ranges	Transport	-25 ... +70°C
	Storage	-25 ... +55°C
	Operation	0 ... +55°C Derate output rated current by 2%/°C above +40°C
Permissible installation height		0 ... 4000 m amsl Derate output rated current by 5%/1000 above 1000 m amsl
Installation		Installation in control cabinet IP54 for operation with "safe standstill" function
Mounting position		Vertically suspended
Free space	Above/below	≥ 50 mm
	To the side	Can be mounted directly side by side without any clearance

General electrical data

EMC	Meets the requirements of EN 61800-3		
Noise emission	Compliance with limit class A to EN 55011 (achieved with application-typical collective filter)		
Noise immunity	Requirements to EN 61800-3		
	Requirement	Standard	Severity
	ESD ¹⁾	EN 61000-4-2	3, i.e. 8 kV for air discharge 6 kV for contact discharge
	Cable-guided high frequency	EN 61000-4-6	10 V; 0.15 ... 80 MHz
	RF interference (housing)	EN 61000-4-3	3, i.e. 10 V/m; 80 ... 1000 MHz
	Burst	EN 61000-4-4	3/4, i.e. 2 kV/5 kHz
	Surge (impulse voltage on mains cable)	EN 61000-4-5	3, i.e. 1.2/50 µs 1 kV phase-phase 2 kV phase-PE
Insulation resistance	Overvoltage category III to VDE 0110		
Discharge current to PE (acc. to EN 50178)	> 3.5 mA AC for operation with appropriate controllers		
Enclosure	IP20 for standard assembly IP20 for assembly in "cold plate technique" IP20 for assembly in "push-through technique" (IP54 on heatsink side)		
Protective measures against	Short circuit, short to earth (protected against short to earth during operation, limited protection against short to earth on mains power-up), overvoltage, motor stalling, motor overtemperature (input for PTC, I ² t monitoring)		
Protective insulation of control circuits	Safe isolation of mains: Double/reinforced insulation to EN 50178; Rated insulation voltage 300 x √2 [V]		

¹⁾ The control cabinet must be able to ensure noise immunity to the degrees of severity listed! The user must check adherence to the degrees of severity listed!

Overview of module selection

To speed up the preselection process, this page contains an overview of all ECS system modules. Additional more detailed information about the individual modules appears on the pages indicated.

ECS□A axis modules

Overview of ECS□A axis modules (data for 400 V mains)							
		ECS□A 004	ECS□A 008	ECS□A 016	ECS□A 032	ECS□A 048	ECS□A 064
I_{Amax}	[A]	4.0	8.0	16.0	32.0	48.0	64.0
I_r (4 kHz)	[A]	2.0	4.0	8.0	12.7	17.0	20.0
$I_{o\ rms}$ (4 kHz)	[A]	2.0	4.0	8.0	16.0	23.0	27.0
S_r	[kVA]	1.1	2.2	5.5	8.8	11.8	13.8
Rated data		Page 2-8					

ECS□E supply modules

Overview of ECS□E supply modules (data for 400 V mains)				
		ECS□E 012	ECS□E 020	ECS□E 040
$I_{mains\ r}$	[A]	9.6	15.9	31.9
$I_{DC\ r\ rms}$	[A]	12.0	20.0	38.5
P_r	[kW]	6.0	10.0	20.0
$P_{brake\ max}$	[kW]	7.8	16.0	31.2
Rated data		Page 2-13		

ECS□K capacitor modules

Rated data page 2-17.



ECSCA032 axis module for 32 A peak current in cold plate design



ECSC E020 supply module for 20 A DC in cold plate design



Features

The compact axis modules are designed for operation in a DC-bus link. Six power stages (I_{Amax} : 4 A to 64 A, P_r : 1.1 to 13.8 kW) ensure optimum operation for dynamic servo applications. Ease and speed of assembly and commissioning was prioritised when designing the modules.

Basic functions of axis controllers

- ▶ **Speed control** via terminal or fieldbus system (terminal, AIF, CAN)
- ▶ **Torque control** via terminal or fieldbus system (terminal, AIF, CAN)
- ▶ **Master frequency follower** via terminal or fieldbus system (terminal, AIF, CAN)¹⁾

Possible control system configurations

- ▶ Motion control systems based on analog setpoints and incremental feedback systems
- ▶ Motion control systems with CAN-based communication options
- ▶ IPC-based motion control systems with at least one of the above setpoint/actual value paths
- ▶ Process control systems which use torque or speed setpoints to control the process (e.g. winder computers, coil winder systems)

Pluggable accessories

- ▶ 9371BC operating module for parameter setting and parameter transfer
- ▶ Serial RS232/485 module via wire or optical fibre 2102IB
- ▶ INTERBUS-S module 2113IB
- ▶ PROFIBUS module 2131IB
- ▶ DeviceNet module 2175IB

Features

- ▶ Field-based control
- ▶ Phase controller, can be integrated¹⁾
- ▶ Direct connection of resolver and encoder, TTL or SinCos encoder
- ▶ Connection option for a second rotary encoder
- ▶ Direct evaluation of a SinCos absolute value encoder
- ▶ Digital synchronisation system via master frequency
- ▶ Individual user configurations
- ▶ Modular function blocks
- ▶ Oscilloscope function (in conjunction with the DriveServer and GDC PC software)
- ▶ Integrated fan (only for built-in unit)
- ▶ IP54 design of the rear of the module (only for push-through technique)
- ▶ Thermal separation (push-through or cold plate technique)
- ▶ Completely pluggable terminals
- ▶ DC-bus connections at the top
- ▶ Motor connections at the bottom
- ▶ 4 digital inputs
- ▶ 1 digital output
- ▶ 1 analog input
- ▶ 24 V brake connection with monitoring
- ▶ "Safe standstill" safety function to EN 954-1 Control Category 3
- ▶ 2 integrated system bus interfaces (CAN)
- ▶ CAN address and baud rate switch
- ▶ Integrated master frequency input or output, can be switched over
- ▶ UL approval
- ▶ CE conformity to Low-Voltage Directive (73/23/EEC)

¹⁾ Additional individual software required



Rated data

	Type ¹⁾	ECS□A004	ECS□A008	ECS□A016	ECS□A032	ECS□A048	ECS□A064
Max. output current (acceleration current)	I_{Amax} [A]	4.0	8.0	16.0	32.0	48.0	64.0
Rated current for 4 kHz ⁵⁾	I_{r4} [A]	2.0	4.0	8.0	12.7	17.0	20.0
Rated current for 8 kHz ⁵⁾	I_{r8} [A]	1.35	2.7	5.3	8.5	11.3	13.3
Continuous current at standstill	$I_{o, rms 4 kHz}$ [A]	2.0	4.0	8.0	16.0	23.0	27.0
Short-time standstill current	$I_{o, rms 4 kHz}$ [A]	3.0	6.0	12.0	24.0	36.0	48.0
Output power at $U_{mains} = 400 V$	S_r [kVA]	1.1	2.2	5.5	8.8	11.8	13.8
DC-bus current	I_{DCr} [A]	2.5	4.9	9.8	15.6	20.9	24.5
DC-bus capacity	[μF]	165	165	165	165	330	330
DC-bus voltage	U_{DC} [V]	0 ... 770					
Max. output frequency	f_{out} [Hz]	600					
Ambient temperature	T_{amb} [°C]	0 ... +55 ³⁾					
Speed of cooling air (only for push-through technique)	$V_{cooling}$ [m/s]	3					
Weight (incl. packaging)	[kg]	2.2				3.1	
Dimensions of cold plate design ^{2) 4) 6)}	(WxHxD) [mm]	88 x 287 x 121				132 x 287 x 121	
Dimensions of built-in unit, push-through technique ^{2) 4)}	(WxHxD) [mm]	88 x 247 x 176				132 x 247 x 176	

¹⁾ "□" indicates the design and should be replaced as follows:

Cold plate: "C"; built-in unit: "E"; push-through technique: "D"

²⁾ The mounting depth of the devices increases by 8 mm when the AIF module is connected (basic height) or by 24 mm when the AIF module 2113 is connected.

³⁾ Derating must be applied by the user at and above 40°C

0°C ... +40°C no power reduction
 +40°C ... +55°C power reduction
 2.0%/K (based on IN)

Permissible installation height h h = 1000 m amsl no power reduction
 1000m amsl < h = 4000 m amsl with
 power reduction 5%/1000 m.

⁴⁾ Dimensions without fastenings or AIF modules

⁵⁾ Please refer to the diagrams on page 2-10 for output frequencies < 5 Hz!

⁶⁾ Please refer to the data for dimensioning the external heatsink on page 2-21 if you are using the cold plate design!



ECSDA048 with PROFIBUS-DP communication module connected (thermal separation design)

Control connections

	Electrical data	Additional notes
Voltage supply, control section	GND, 24 V DC, 0.5 A ¹⁾	20 ... 30 V DC
4 x digital input	24 V DC	can be parameterised
Digital output	24 V DC, 0.7 A	protected against short circuits, I _{max} 1.4 A
Safe standstill	24 V DC	2x input, 1x output, 1x voltage supply, 18 ... 30 V DC
Motor holding brake	24 V DC, 1.5 A	18 ... 30 V DC
Analog input	-10 V ... +10 V or -20 mA ... +20 mA	configurable
Communication interface	2x CAN bus	on-board
Resolver input	9-pin SUB-D	
Encoder connection	9-pin SUB-D	can be switched over as: 1) Encoder input 2) Encoder simulation 3) Encoder output

¹⁾ The current requirement of the digital output may need to be included when dimensioning a 24 V supply for this connection.

All control connections are electrically isolated from the device ground. All control connections have a common reference potential.

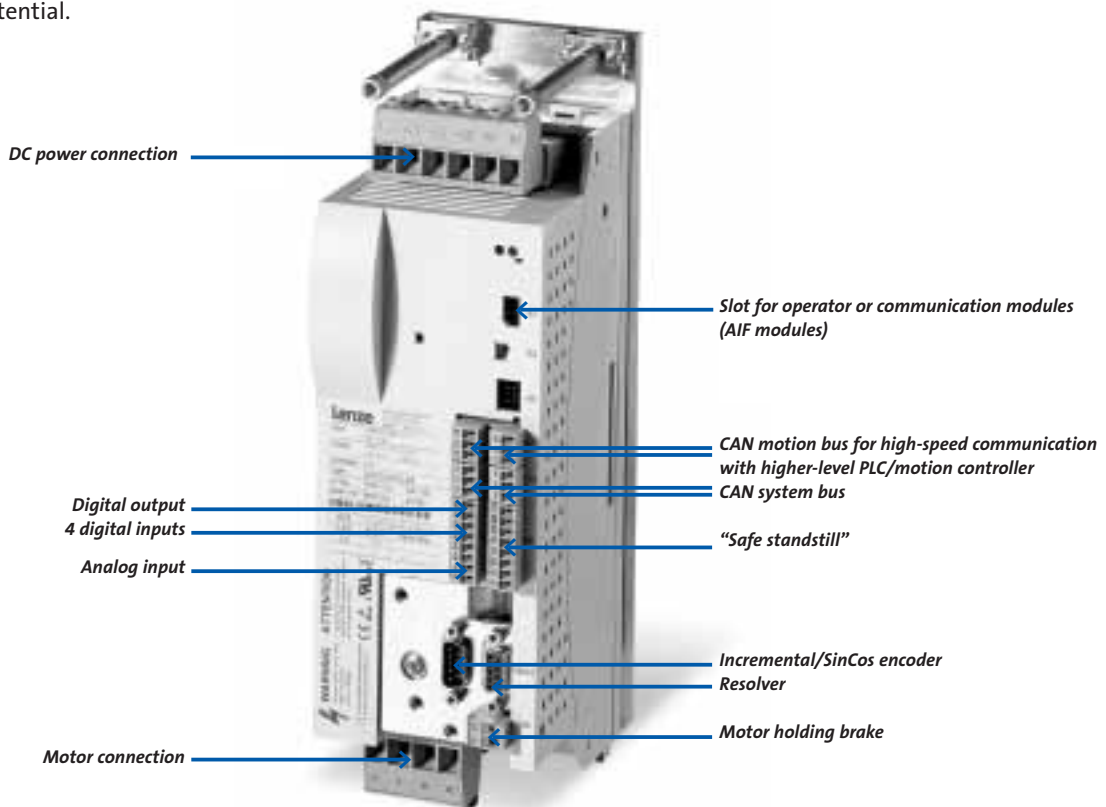

ECS module power and control connections, pluggable (the illustration shows an ECSCA008 axis module in cold plate design)

Characteristics for maximum output currents

The axis controllers work with switching frequencies of 4 and 8 kHz. At field frequencies < 5 Hz, the output current is derated on the controllers.

If the characteristic for 8 kHz is exceeded by the current, the frequency is automatically switched down to 4 kHz. The output current is limited when the 4 kHz characteristic is reached.

If a heatsink temperature of 70°C is exceeded, the switching frequency is also reduced to 4 kHz. It switches back to 8 kHz with a hysteresis of 5°C.

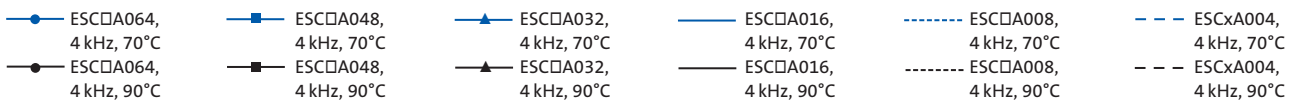
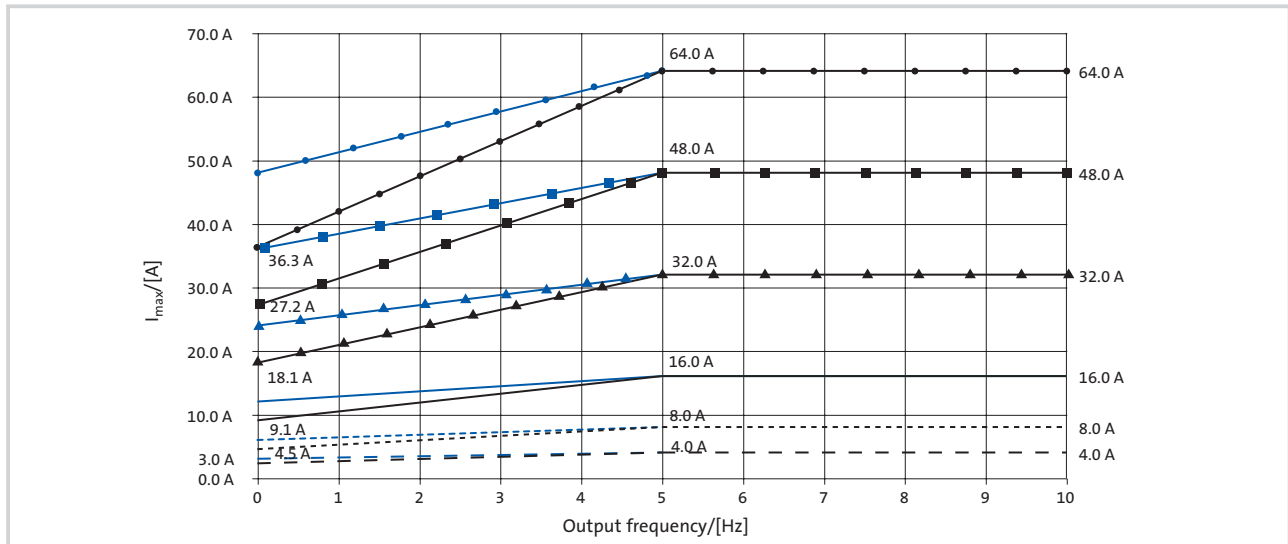

Device currents in the range 0 ... 10 Hz output frequency ($f_{\text{chop}} = 4 \text{ kHz}$)

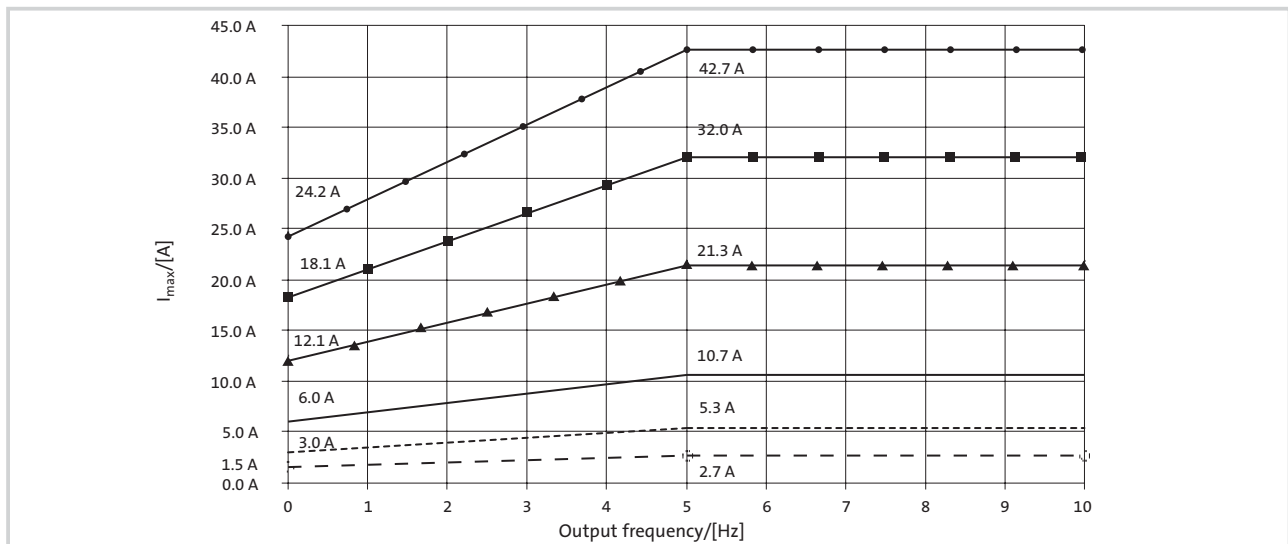

Device currents in the range 0 ... 10 Hz output frequency ($f_{\text{chop}} = 8 \text{ kHz}$)

Type codes for ECS□A axis modules



Ordering example:

ECS axis modules, thermal separation (push-through technique), peak current 32 A, CAN system bus, for 400 V mains, standard design
 Order number: ECSDA032 C4B

Features

The supply units provide the DC voltage for the axis controllers. In terms of size and structure, they are identical to the axis controllers and can be mounted directly alongside the axis controllers.

The following designs are available:

- ▶ Built-in unit (wall mounting) with integrated fan
- ▶ Push-through technique (thermal separation) without integrated fan
- ▶ Cold plate

Features:

- ▶ Generation of DC-bus voltage for a drive controller network
- ▶ Speedy assembly/disassembly, e.g. because all terminals can simply be plugged in
- ▶ Address/ baud rate switch for system bus
- ▶ Controlled charging of DC bus
- ▶ Communication via integrated system bus (CAN) interface for process data parameter settings and transfer
- ▶ Communication via AIF for parameter setting
- ▶ Internal brake chopper
- ▶ Internal brake resistor with monitoring (not for cold plate)
- ▶ Alternative connection option for external brake resistor with thermostat
- ▶ Automatic detection of mains voltage with adaptation of brake chopper switch-on voltage
- ▶ Checking of the DC bus on power-up for short to earth and short circuit
- ▶ Phase-specific mains failure monitoring
- ▶ Monitoring of mains current
- ▶ 2 digital inputs, 1 digital output (floating)



ECSD E020, push-through technique



ECSE E040, built-in unit

Rated data

The supply module is approved only for operation on symmetrical systems. Operation on systems with earthed phase conductor is not permitted.

The unit is fitted with an automatic mains voltage detection function with adaptation of the brake chopper switch-on voltage.

Supply units	Type	ECS□E012 ¹⁾	ECS□E020 ¹⁾	ECS□E040 ¹⁾
Mains voltage	U_{mains} [V]	3x 180 ... 3x 528 ±0%; 45 Hz ... 65 Hz ±0%		
Mains rated voltage	$U_{\text{mains r}}$ [V]	3x 400		
Mains rated current	$I_{\text{mains r}}$ [A]	9.6	15.9	31.3
Maximum mains current		Max. 5x mains rated current for 50 ms, 2x mains rated current for 1 s 1.5x mains rated current for 10 s ²⁾		
Rated direct current (effective value)	$I_{\text{DC r,eff}}$ [A]	12.0	20.0	38.5
Output power 400 V mains	P_r [kW]	6.0	10.0	20.0
Brake chopper resistance, internal ⁴⁾	R_B [Ω]	82.0	39.0	20.0
Brake chopper resistance, external	R_B [Ω]	≥ 82.0	≥ 39.0	≥ 20.0
Max. braking power with int./ext. brake resistor ⁴⁾	$P_{B, \text{max}}$ [kW]	7.6	16.0	31.2
Continuous braking power with int. brake resistor ⁴⁾	$P_{\text{BD, int}}$ [kW]	0.10	0.12	0.15
Continuous braking power with ext. brake resistor	$P_{B, \text{ext}}$ [kW]	2.0	3.0	6.0
Ambient temperature	T_{amb} [°C]	0 ... +55 ³⁾		
Speed of cooling air	V_{cooling} [m/s]	3		
Weight (incl. packaging)	[kg]	2.5		3.0
Dimensions of cold plate design ^{6) 7)}	(WxHxD) [mm]	88.5 x 287 x 121		131 x 287 x 121
Dimensions of built-in unit, push-through technique ⁷⁾	(WxHxD) [mm]	88.5 x 247 x 176		131 x 247 x 176

¹⁾ "□" indicates the design and should be replaced as follows:

Cold plate: "C"; built-in unit: "E"; push-through technique: "D"

²⁾ The maximum currents indicated are valid for the following continuing switch-on conditions:

5x mains rated current 4% I_{max} , 96% $I = 0$
 2x mains rated current: 25% I_{max} , 75% $I = 0$
 1.5x mains rated current: 44% I_{max} , 56% $I = 0$

³⁾ Derating must be applied by the user at and above 40°C

-10°C ... +40°C no power reduction
 +40°C ... +55°C power reduction

2.0%/K (based on IN)

Permissible installation height h h = 1000 m amsl no power reduction
 1000 m amsl < h = 4000 amsl with.

⁴⁾ The internal brake resistor indicated here is integrated into the heatsink on the "built-in unit" (order designation ECSE□□□□) and "thermal separation" (order designation ECSDE□□□□) designs. On the "cold plate" design (order designation ECSCE□□□□), an external resistor must be used instead.

An external resistor is also required if the continuous braking power of the built-in resistor is exceeded.

External brake resistors are described on page 3-9.

⁶⁾ Please refer to the data for dimensioning the external cooler on page 2-21 if you are using the cold plate design!

⁷⁾ The height of the units increases by 8 mm when the communication module is plugged in.

Control connections

Function	Electrical data	Additional notes
Voltage supply, control section	GND, 24 V DC, 0.5 A ¹⁾	20 ... 30 V DC
Digital input mains enable	24 V DC	
Digital input controller enable	24 V DC	
Digital output, ready for operation and controller enable	24 V DC, 0.7 A	protected against short circuits, I_{max} 1.4 A
Thermostat, contact 1		
Thermostat, contact 2		

¹⁾ The current requirement of the digital output may need to be included when dimensioning a 24 V supply.

All control connections are electrically isolated from the device ground. All control connections have a common reference potential.

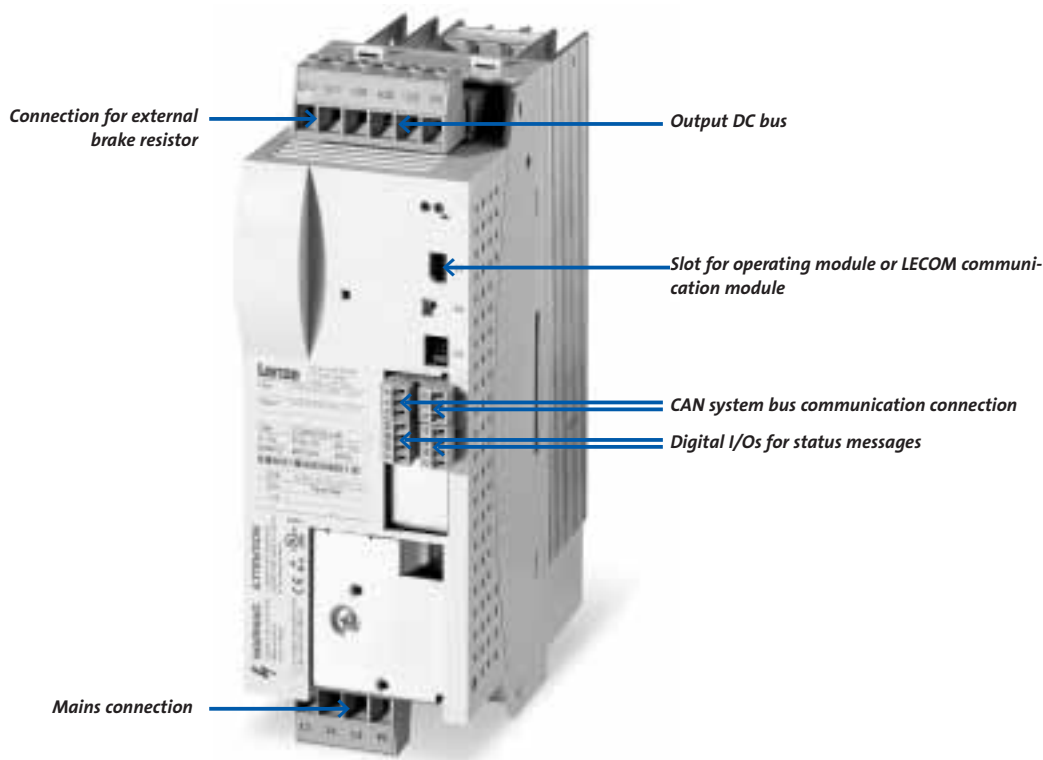

Pluggable power and control connections for ECS supply modules (the illustration shows an ECSEE020, built-in version)

Type codes for ECS□E supply modules

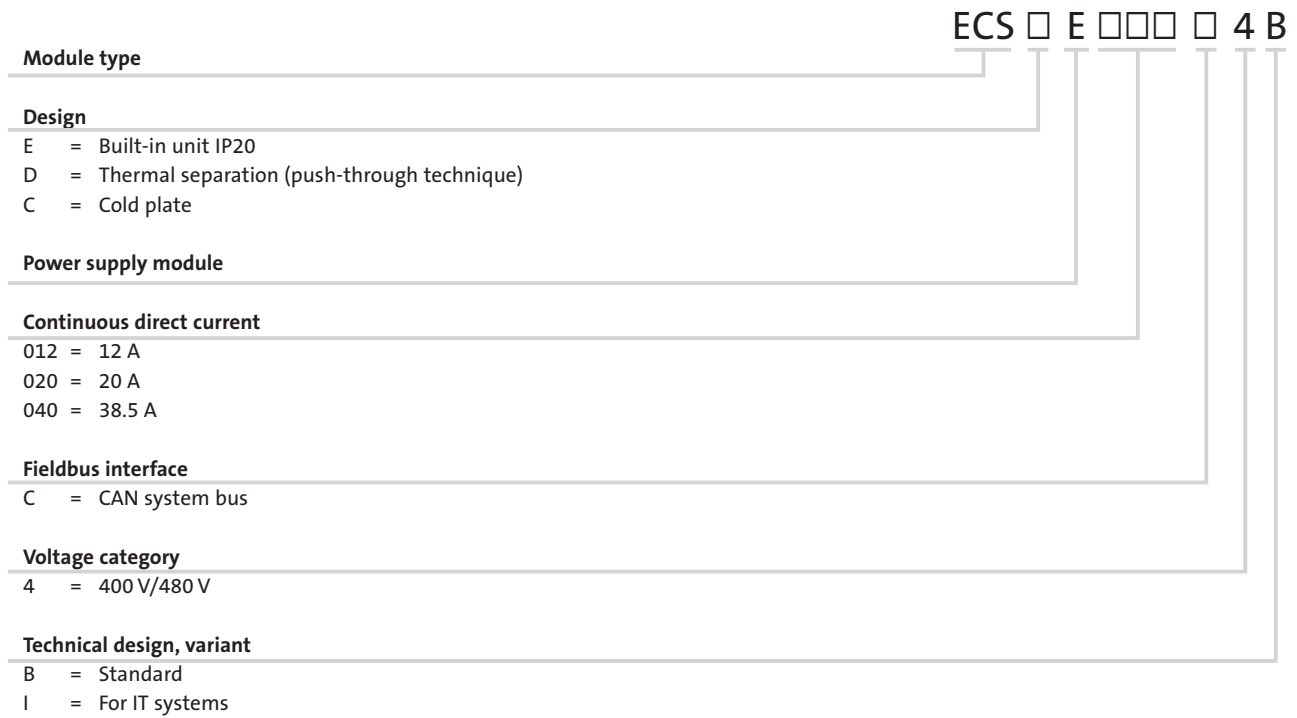

Ordering example:
ECS supply module, built-in unit, continuous direct current
20 A, CAN system bus, 400 V voltage, standard mains
Order number: ECSEE020C4B

Features

The ECS servo system is ideal for use in dynamic multi-axis applications. As, depending on the specific conditions, operating modes may be used in these applications which require significantly increased DC-bus power for long periods of time, ECS□K capacitor modules have been provided. These modules will optimise the dimensioning of the required DC-bus capacity for the specific application.

Use the following formula for a preliminary assessment of whether a capacitor module is required:

$$\frac{\text{Total capacity of DC-bus connection } [\mu\text{F}]}{\text{Temporal average of total rated power of all drives } [\text{kW}]} = k_c \frac{[\mu\text{F}]}{[\text{kW}]}$$

If $k_c \geq 100 \text{ } [\mu\text{F}/\text{kW}]$, an additional capacitor module will not generally be required.

Example:

Three axes with a cyclical positioning operation with delta profile and a pause with the following time ratio:

Accelerate: Brake: Pause = 1:1:1

The following equation applies for this travel profile ¹⁾: Average power = Power required x 0.222

Assumption:

Axis modules used:

Sum of DC-bus capacities (see page 2-8):

Average power:

Power required 2x 2.2 kW + 1x 5.5 kW

2x EXS□A008 and 1x ECS□A016

3x 165 μF = 495 μF

((2x 2.2 kW) + 5.5 kW) x 0.222 = 2.2 kW

$$k_c = \frac{495 \mu\text{F}}{2.2 \text{ kW}} = 225 \frac{[\mu\text{F}]}{[\text{kW}]}$$

As $k_c > 100 \text{ } \mu\text{F}/\text{kW}$, a capacitor module does not have to be used.

Should you have any questions about calculations, please contact your local Lenze sales representative, who will be happy to help you.

¹⁾ Please see the relevant formula collection for more detailed calculation information.

Rated data

Capacitor module	Type ¹⁾	ECS□K001	ECS□K002
Capacity	[μF]	705	1410
Rated power	[kW]	10.0	20.0
DC-bus voltage	U _{DC} [V]	0 ... 770	
Ambient temperature	T _{amb} [°C]	0 ... +55	
Speed of cooling air (only for push-through technique)		No specific measures required	
Weight (incl. packaging)	[kg]	2.0	3.1
Dimensions without fastenings or AIF modules	(WxHxD)		
Cold plate		88.5 x 286 x 121	132 x 286 x 121
Built-in unit, push-through technique	[mm]	88.5 x 247 x 176	132 x 247 x 176

¹⁾ "□" indicates the design and should be replaced as follows:
Cold plate: "C"; built-in unit: "E"; push-through technique: "D"

Connections for ECS□K capacitor modules



Pluggable power and control connections for ECS capacitor modules (the illustration shows an ECSDK01 in push-through technique)

ECS E□ built-in unit

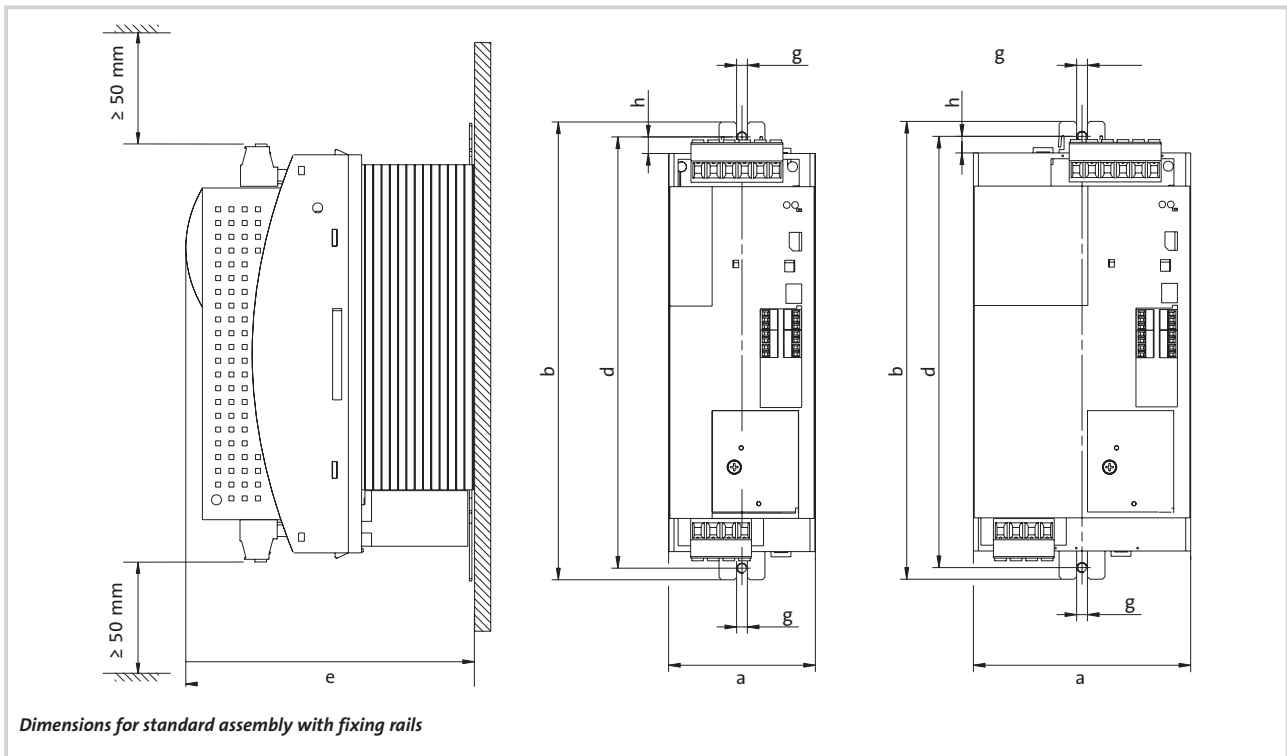

Type	Frame size	Dimensions [mm]					
		a	b	d	e	h	g
ECSEA004	1	88.5	276	260	174 ¹⁾²⁾	10	6.5 (M6)
ECSEA008							
ECSEA016							
ECSEA032							
ECSEE012							
ECSEE020	2	131					
ECSEA048							
ECSEA064							
ECSEE040							
ECSEK001							
ECSEK002							

¹⁾ Dimension "e" without fastenings or AIF module

²⁾ Dimension "e" increases by 8 mm when the AIF module is connected (basic height) or by 24 mm when the AIF module 2113 is connected.

ECS D □, push-through technique (with thermal separation)

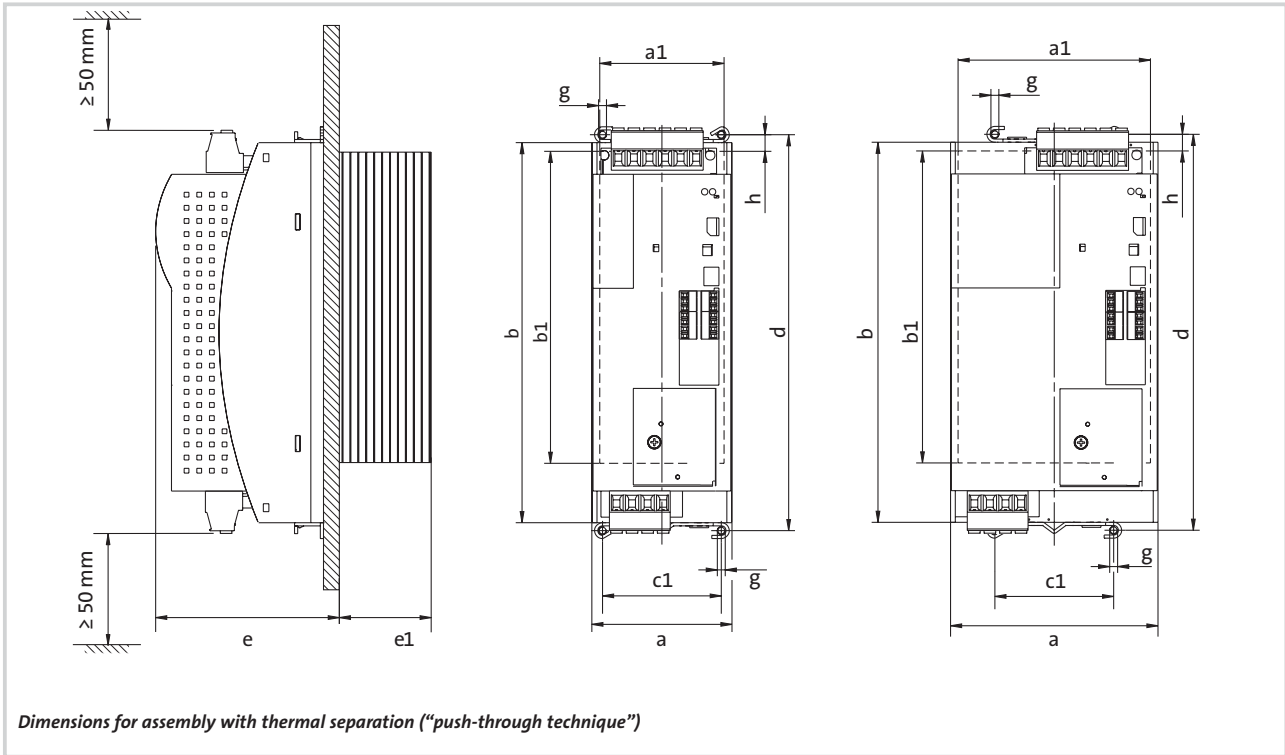

Type	Frame size	Dimensions [mm]									
		a	a1	b	b1	c1	d	e	e1	h	g
ECSDA004	1	88.5	78.5	240	197	75	250	116 ¹⁾²⁾	58	10.5	M5
ECSDA008											
ECSDA016											
ECSDA032											
ECSDA048											
ECSDA064	2	131	121.5	240	197	75	250	116 ¹⁾²⁾	58	10.5	M5
ECSDA048											
ECSDA064											
ECSDA064	2	131	121.5	240	197	75	250	116 ¹⁾²⁾	58	10.5	M5
ECSDA064											
ECSDA064	2	131	121.5	240	197	75	250	116 ¹⁾²⁾	58	10.5	M5
ECSDA064											

¹⁾ Dimension "e" without fastenings or AIF module

²⁾ Dimension "e" increases by 8 mm when the AIF module is connected (basic height) or by 24 mm when the AIF module 2113 is connected.

In order to provide sufficient cooling for the drive system, an air flow with a flow velocity of at least 3 m/s is required behind the backplane of the control cabinet.

ECS C□, cold plate design

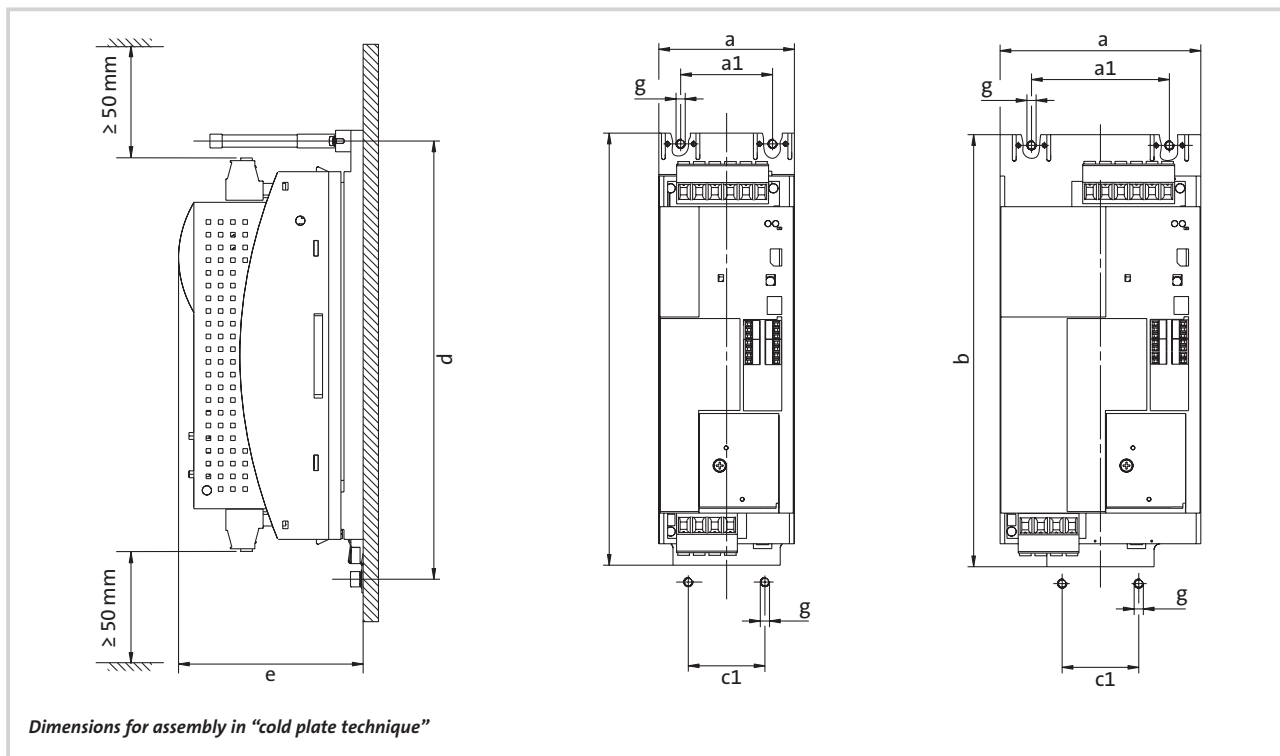

		Dimensions [mm]						
Type	Frame size	a	a1	b	c1	d	e	g
ECSCA004	1	88.5	60	282	50	286	121 ¹⁾²⁾	M6
ECSCA008								
ECSCA016								
ECSCA032								
ECSCA048								
ECSCA064	2	131	90					
ECSCA064								
ECSCA064								
ECSCA064								
ECSCA064								
ECSCA064								
ECSCA064								

¹⁾ Dimension "e" without fastenings or AIF module

²⁾ Dimension "e" increases by 8 mm when the AIF module is connected (basic height) or by 24 mm when the AIF module 2113 is connected.

The following conditions must be met for the safe operation of cold plate design axis modules:

- ▶ Evenness of contact surface of cooler: ≤ 0.5 mm
- ▶ Roughness of contact area: $R_a = 0.8$
- ▶ Good thermal connection to cooler
- ▶ The entire cooling surface of the axis module must make contact with the collective cooler
- ▶ Temperature of cold plate below $+85^{\circ}\text{C}$
- ▶ Do not exceed the thermal resistance R_{th} specified in the table. The values are valid when operating the axis modules under rated conditions.

Type	R_{th} [K/W]
ECSCA004	0.31
ECSCA008	
ECSCA016	
ECSCA032	0.13
ECSCA048	
ECSCA064	0.11
ECSCE012	0.45
ECSCE020	0.34
ECSCE040	0.17

There are no specific specifications to be observed for ECSCK modules.

The ECS servo system axis modules can be used in a wide variety of applications. In order to ensure simple and efficient configuration and commissioning under all circumstances, the axis module application software has been divided into task-specific “Speed and Torque”, “Posi and Shaft” and “ETC001” packages.

These software packages have been designed specifically for operation in a multi-axis grouping controlled by a PLC, a motion control controller or a PC-based control system and ensure precise control cycle synchronisation for all axes to the microsecond.

If a customer requires a specific solution for an application which cannot be handled using these standard solutions, this is also possible. Please contact your local Lenze sales representative for more information.

Speed and Torque

This application software provides the basic functions for speed and torque control. Relevant setpoints can be specified either manually, via analog values or serially via the CAN bus (or other bus systems). Up to 15 default speed setpoints can also be used. Ramps for the selection of new setpoints can be linear or S-shaped. In the event of a quick stop, drift-free standstill is assured. As standard, the package also features the “safe standstill” function to EN 954-1, Category 3 and supports the control of a motor holding brake with a monitoring function.

Posi and Shaft

This application software can be used to predefine and save up to 15 positioning profiles. Positioning can be absolute, relative, modulo (i.e. relative and infinite) or based on a manual fixed speed value or master frequency follower. Various forms of touch probe positioning are also supported as well as torque derating once the target position has been reached and speed override. In addition to eight different options for referencing, the “safe standstill” and motor holding brake logic are also standard features.

ETC001

The ETC001 application software has been designed specifically for multi-axis groupings controlled by an ETC motion control controller. It features a CAN motion bus angular follower with two different modes as well as position value detection (touch probe). Eight different referencing modes, two types of interpolation (linear and 2nd order polynomial) and torque precontrol are also available to the user. In addition, the “safe standstill” and motor holding brake logic are also standard features.

All ECS axis modules are supplied with the “**Speed and Torque**” application software loaded **on delivery**.

The “Speed and Torque”, “Posi and Shaft” and “ETC001” application software packages can be downloaded free of charge from Lenze's Internet site and can be transferred to the axis modules using the Global Drive Loader PC software (see page 3-20).





System accessories | ECS servo system

Operating module/ PC system bus adapter	3-2	Connectors	3-16
Communication		Shield terminals	3-17
Communication modules for LECOM system interface	3-3	PC software	
Communication module for PROFIBUS-DP	3-4	Operating and configuration software	
Communication module for CANopen/DeviceNet	3-4	Global Drive Control	3-18
Communication module for INTERBUS	3-5	Global Drive oscilloscope	3-19
Communication module for LON	3-5	Standard set-up program	
		Global Drive Loader	3-20
Mains chokes	3-6	Automation components	
RFI filters for limit class A	3-8	I/O system to IP20	3-21
		Human machine interfaces	3-22
External Brake resistors	3-9	Drive PLC	3-23
System cables	3-14	ETC motion control controller	3-24
Cable protection fuses	3-15	Regenerative power supply modules	3-25

System accessories

Operating module/PC system bus adapter

Operating module

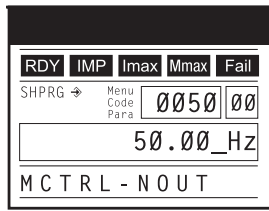

The Keypad XT is available for visualisation and for entering parameters and codes. 8 keys and a text display speed up access to all parameters for the axis and supply modules in the ECS servo system via the transparent menu structure. The Keypad XT is also used for status display, error diagnostics and, with its built-in memory, for the transmission of parameters to other modules.

The Keypad XT can also be used on 8200 vector, 9300 vector, 9300 servo and Drive PLC devices as well as on 8200 motec decentralised motor inverters (via the diagnosis terminal).

See our "Automation" catalog (ID no. 494 445) for more detailed information about design formats, control cabinet door installation options, operation as a diagnosis terminal and accessories.

Keypad XT

Order number **EMZ9371BC**

PC system bus adapter

The PC system bus adapter provides a quick and easy means of connecting the PC to the Lenze system bus (CAN) for setting parameters on and programming the controller.

For the printer port

This adapter simply plugs into the PC's parallel port. The relevant drivers are installed automatically with the appropriate Lenze software. Depending on the version, the voltage supply is provided via the DIN or PS2 connection on the PC.

Order no.	Brief description
EMF2173IB ¹⁾	System bus adapter; voltage supply via DIN connection on PC
EMF2173IB V002 ¹⁾	System bus adapter; voltage supply via PS2 connection on PC
EMF2173IB V003 ¹⁾	System bus adapter; voltage supply via PS2 connection on PC; electrically isolated from the CAN bus



EMF2173IB V003

For the USB port

This adapter simply plugs into the PC's USB port. The relevant drivers are installed automatically with the appropriate Lenze software. The voltage supply is provided by the USB port on whichever PC/laptop is used.

Order no.	Brief description
EMF2177IB ¹⁾	USB system bus adapter; voltage supply also provided via the USB connection on the PC; electrically isolated from the CAN bus as standard

Please note: The Microsoft® Windows® NT operating system does not support the USB interface.

¹⁾ A CAN connecting cable (5 m) is included in the scope of supply



EMF2177IB

The ECS servo system supply and axis modules can be networked with a host system (PLC or PC) via pluggable communication modules.

The modules are connected instead of the operating module.

The following combinations are possible:

	LECOM				PROFIBUS-DP	CANopen DeviceNet	LON	INTERBUS
	-A/B	-B	-A	-LI				
Axis modules ECS□A	●	●	●	●	●	●	●	●
Supply modules ECS□E	●	●	●	●	—	—	—	—
Capacitor modules ECS□K	○	○	○	○	○	○	○	○

- Combination possible
- Combination not possible
- Communication not required

Communication modules for LECOM system interface

If another Lenze system bus interface is required in addition to the CAN interfaces for the motion bus and system bus integrated as standard into the axis and supply modules, four types are available to meet varying requirements.



	LECOM-A/B	LECOM-B	LECOM-A	LECOM-LI
	Ideal for simple parameter setting with GDC	Suitable for universal use with the open Lenze protocol for PC-PLC interfacing	Absolutely ideal for simple parameter setting with GDC. Voltage supplied internally from the ECS module	High noise immunity data transmission via optical fibres
Interface	RS232/RS485	RS485	RS232	OF
Baud rate	19.2 kB	19.2 kB	19.2 kB	19.2 kB
Max. length	A: 15 m/B: 1000m	1000 m	15 m	40 m per segment
Topology	Point-to-point/line	Line	Point-to-point	Ring
Max. no. of stations	2/32	32	2	52
Order number	EMF2102IBC001	EMF2102IBC002	EMF2102IBC004	EMF2102IBC003

Communication module for PROFIBUS-DP

The PROFIBUS-DP module is a slave connection module with the PROFIBUS-DP communication profile. It is used for networking between control system and inverter at high processing speeds. It provides a user-friendly way of integrating the inverter into the overall system network. The Lenze PROFIBUS module has been certified by the PNO. Addresses can be allocated easily via DIP switches.



Interface	RS485
Baud rate	9.6 ... 12.000 kBaud (automatic detection)
Max. bus length	1000 m (depends on baud rate)
Topology	Line (with repeaters also tree)
Max. no. of stations	32 (with repeaters max. 125 total)
Order number	EMF2133IB

Communication module for CANopen/DeviceNet

The DeviceNet fieldbus has been particularly successful in the American and Asian markets. The Lenze CANopen/DeviceNet module can function in two operating modes - DeviceNet and CANopen.

The DIP switch on the front panel of the function module can be used to make the following settings:

- ▶ Station address
- ▶ Baud rate
- ▶ Communication profile: DeviceNet or CANopen



Interface	DIN ISO 11898
Baud rate	500 kBaud
Max. bus length	1000 m (depends on baud rate)
Topology	Line (with repeaters also tree)
Max. no. of stations	63
Order number	EMF2175IB

Communication module for INTERBUS

The INTERBUS connection is made directly on the remote bus. The remote bus module power supply can be provided either internally or externally.



	INTERBUS (remote bus)
Baud rate	500 ... 2000 kB
Process data words	10 ¹⁾
Parameter data words	0, 1, 2 or 4 ¹⁾
Drive profile	Lenze device control DRIVECOM profile Drive technology 21
Voltage supply	Internal or external
Order number	EMF2113IB

¹⁾ The total for the process and data words must be ≤ 10 .

Communication module for LON

The LON fieldbus is primarily used in building services systems.

The Lenze communication module adds the LONMARK functional profile "Variable Speed Motor Drive" to the functionality of the inverter. The communication status is displayed via two LEDs on the communication module.



Interface	FTT
Baud rate	78 kBaud
Max. bus length	2000 m (without repeaters)
Topology	Line, tree, star, ring
Max. no. of stations	32385 (64 per segment)
Order number	EMF2141IB

A mains choke does not necessarily have to be installed in order to operate the ECS servo system. Checks should be made on a case-by-case basis to ascertain whether a mains choke needs to be installed. However, the use of a mains choke does offer the user the following advantages:

- ▶ Reduced mains disturbance
- ▶ The wave form of the mains supply is a closer approximation of a sine wave
- ▶ Reduction in the r.m.s. mains current by up to 25%
- ▶ Reduction in mains, line and fuse load
- ▶ Reduction in low-frequency radio interference voltages

Please note the following if you are using a mains choke:

- ▶ The maximum possible output voltage does not reach the full value of the mains voltage.
- ▶ If you are running acceleration drives with high peak currents, the use of Lenze mains chokes type ELN3 with linear L/I characteristic is recommended.



Mains choke for ECS supply modules

ECS supply module	Mains choke Order number	I_{rated}	L_{rated}	U_k
ECS□E012	ELN3-0150H024	3x 24 A	3x 1.5 mH	4.9 %
ECS□E020	ELN3-0088H035	3x 35 A	3x 0.88 mH	4.2 %
ECS□E040	ELN3-0055H055	3x 55 A	3x 0.55 mH	4.1 %

Dimensions

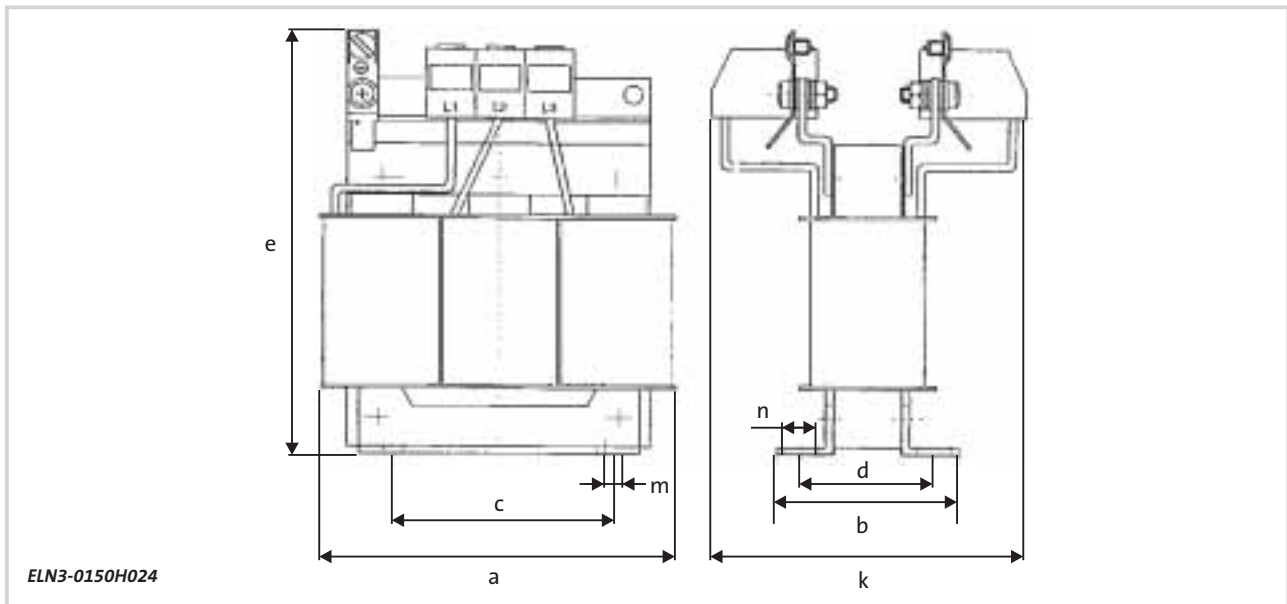

Type	Dimensions [mm]								
	a	b	c	d	e	f	k	m	n
ELN3-0150H024	180	86	136	67	192	–	120	7	12

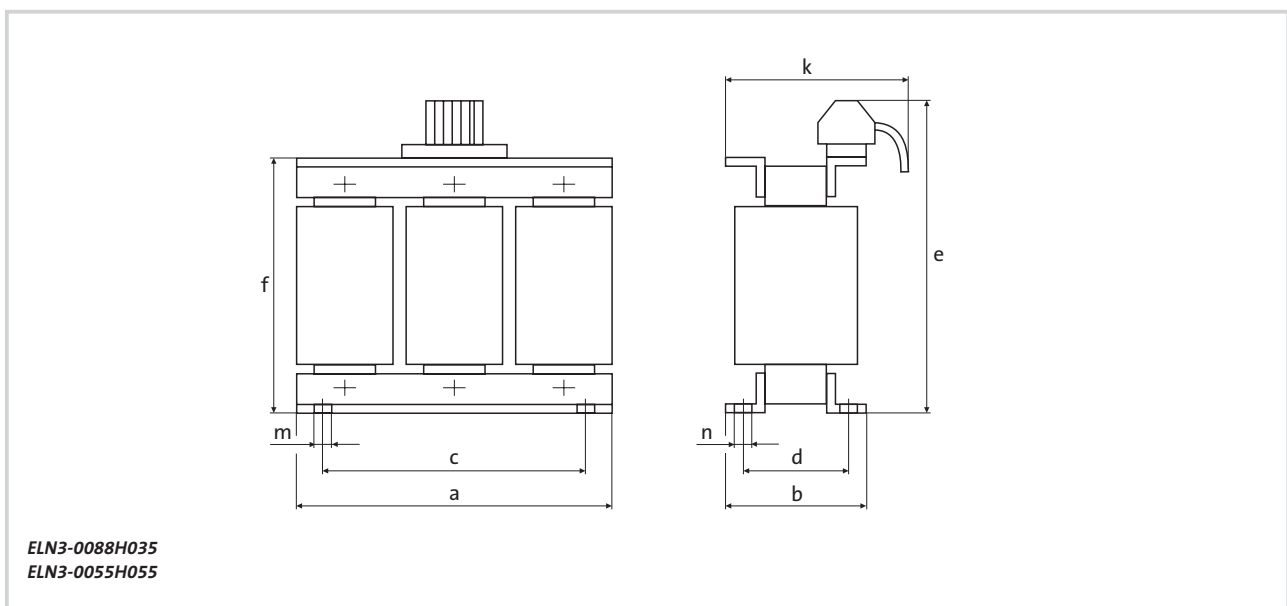

Type	Dimensions [mm]								
	a	b	c	d	e	f	k	m	n
ELN3-0088H035	180	91	161	74	225	165	120	6.3	11
ELN3-0055H055	228	88	206	69	263	205	120	6.3	11

System accessories

RFI filters for limit class A

The measures required for servo systems on the mains side in order to reduce the mains current and for interference suppression will vary depending on the area of application. Although these measures are not usually essential, they will enable universal use of a servo system.

There are two limit classes for electromagnetic interference. Limit class A is required for industrial networks connected directly to the public supply system (no plant power supply transformer). Limit class B applies in residential areas. The use of Lenze mains filters type ECSZZ ensures adherence to the requirements of limit class A.

The RFI filters are designed for the assigned ECS supply module and up to 10 axis modules, each with 25 m of motor cable (Lenze system cable). If your motor cables are longer than 25 m, please contact your local Lenze sales representative.



ECS supply module	Mains filter Order number
ECS□E012	ECSZZ 020X4B
ECS□E020	ECSZZ 020X4B
ECS□E040	ECSZZ 040X4B

Dimensions of Lenze mains filter type ECSZZ

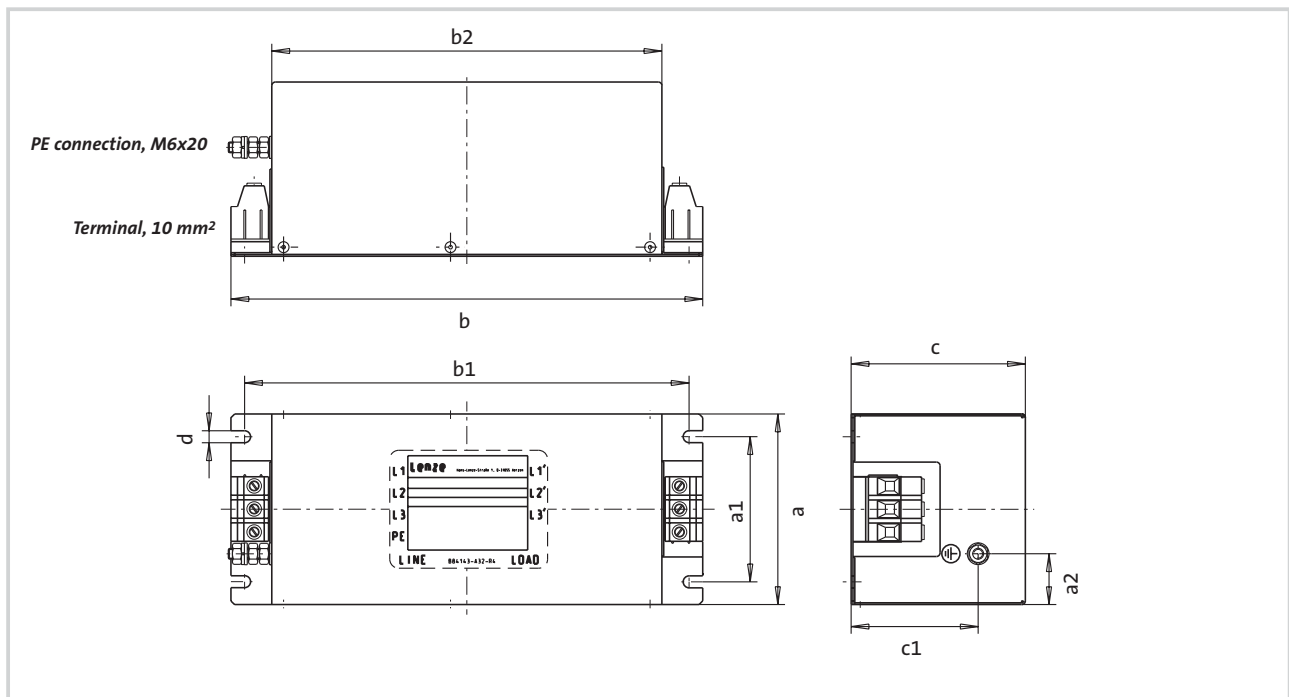

Order number	I_r	U_{mains}	P_V	m	a	$a1$	$a2$	b	$b1$	$b2$	c	$c1$	d
	[A]	[V]	[W]	[kg]	[mm]	[mm]	[mm]	[mm]	[mm]	[mm]	[mm]	[mm]	[mm]
ECSZZ 020X4B	16	500	6.2	3.0	105	80	28	260	245	215	96	70	6.6
ECSZZ 040X4B	32	500	9.3	3.0	105	80	28	260	245	215	96	70	6.6

All ECS□□□□ supply modules feature an integrated brake transistor as standard. “Built-in” and “thermal separation” (push-through technique) ECS supply modules also feature a brake resistor fixed permanently in the heatsink. If the power of the built-in brake resistor is not sufficient (e.g. extremely long brake phases), external brake resistors can also be connected to all supply modules.

Depending on application-specific conditions, an external brake resistor may need to be fitted to cold plate supply modules (ECSCE□□□), as these modules are not designed with a built-in brake resistor as standard. For each of these applications, we can provide a selection of resistors with pulse performance specifically tailored to each supply unit.

In addition, in order to provide adequate protection against impermissible heat rise in the brake resistors whatever the operating conditions, all brake resistors are fitted with a thermal sensor as standard which will send an appropriate warning message in advance to the axis module concerned.

	Brake resistor Order number	ECS□□									Rated data	
		012			020			040				
		ECS□EE	ECS□DE	ECS□CE	ECS□EE	ECS□DE	ECS□CE	ECS□EE	ECS□DE	ECS□CE		
External resistors for “cold plate” supply modules	ERBM082R100W			●								Page 3-10
	ERBM039R120W						●					
	ERBM020R200W										●	
Increased power external resistors	ERBD082R600W	●	●	●								Page 3-11
	ERBD047R01K2				●	●	●					
	ERBD022R03K0							●	●	●		
Increased power external resistors with IP65 enclosure	ERBS082R780W	●	●	●								Page 3-12
	ERBS039R01K2				●	●	●					
	ERBS022R03K2							●	●	●		



ERBM...



ERBD...



ERBS...

External brake resistors for cold plate supply modules type ERBM

As ECSCE (cold plate) supply modules are not designed with a separate heatsink, the module does not feature a built-in brake resistor. In terms of their dimensioning, type ERBM brake resistors are exactly identical to the brake resistors integrated into the heatsinks on type ECSEE and ECSDE supply modules.

These resistors are recommended for use in applications with short pulse-type loads.

The resistors are housed in IP50 enclosures.

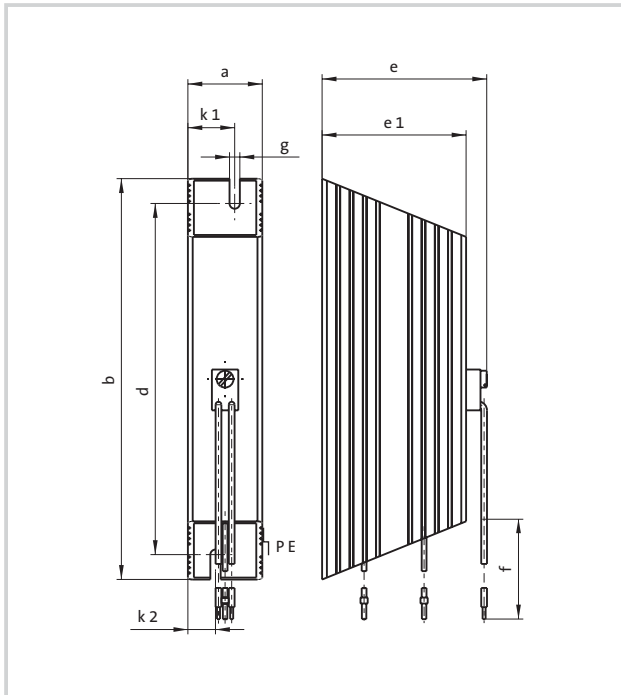

Brake resistor type ERBM

Brake resistor Order number	Dimensions [mm]								
	a	b	d	e	e1	f	g	k1	k2
ERBM082R100W	31	217	200	68	60	700	5.3	19.5	11.5
ERBM039R120W		267	250						
ERBM020R150W		337	320						

Brake resistor Order number	Resistance [Ω]	Permanent power [W]	Thermal capacity [kWs]	m [kg]
ERBM082R100W	82	100	3	0.72
ERBM039R120W	39	120	6	0.91
ERBM020R150W	20	150	13	1.1

The above data requires an OT of approx. 5% with a maximum cycle time of 95 s (5 s braking/90 s idling).

PE connection: 6.3 mm flat connector.

Brake resistors with increased permanent power, type ERBD

Type ERBD increased power brake resistors are used wherever high braking energies are required for long periods of time (e.g. in hoist applications). Type ERBD brake resistors are housed in **IP20 enclosures**.

Increased power brake resistors in **IP65 enclosures** appear on page 3-12.

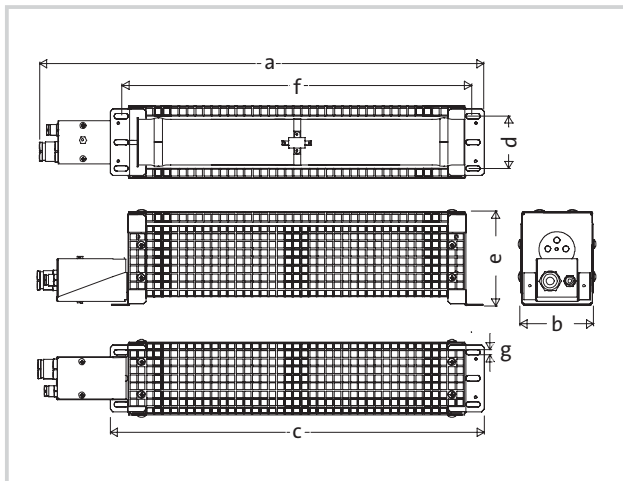

Brake resistor type ERBD

Brake resistor Order number	Dimensions [mm]							
	a	b	c	d	e	f	g	h
ERBD082R600W	640	89	554	64	115	526	6.5	13
ERBD047R01K2	640	177	554	150	115	526	6.5	13
ERBD022R03K0	740	177	654	150	229	626	6.5	13

Brake resistor Order number	Resistance [Ω]	Permanent power [kW]	Peak power [kW]	Thermal capacity [kW·s]	m [kg]
ERBD082R600W	82	0.6	5.8	90	3.1
ERBD047R01K2	47	1.2	11.6	180	4.9
ERBD022R03K0	22	3.0	25.0	450	10.6

The above peak power is valid for a maximum OT of 10% with a maximum cycle time of 150 s (15 s braking/ 135 s idling).

Increased power brake resistors in IP65 enclosure, type ERBS

Type ERBS increased power brake resistors in IP65 enclosures are used wherever high braking energies are required for long periods of time (e.g. in hoist applications) and the harsh environmental conditions necessitate a high type of protection.

Increased power brake resistors in IP20 enclosures appear on page 3-11.

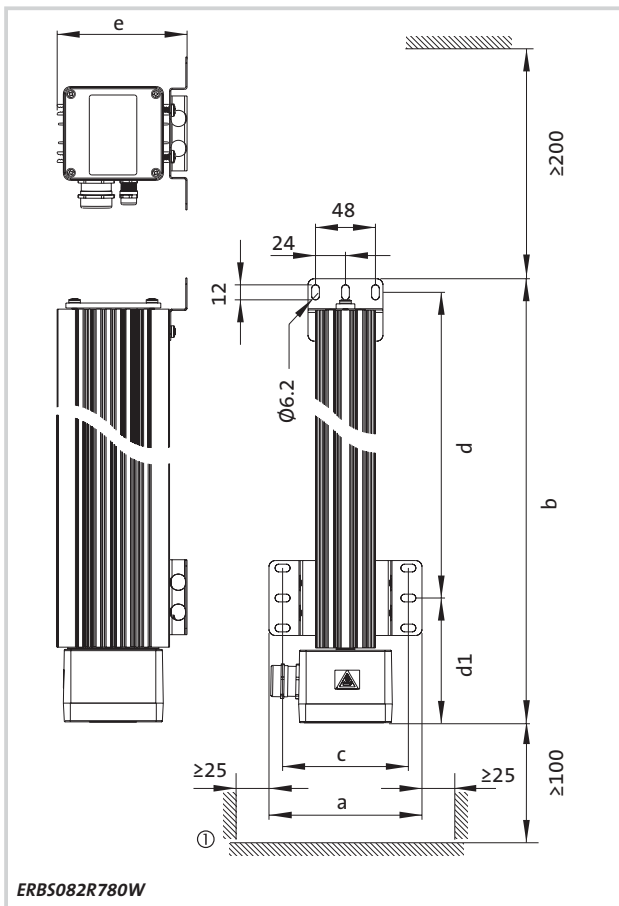

Brake resistor type ERBS

Brake resistor Order number	Dimensions [mm]					
	a	b	c	d	d1	e
ERBS082R780W	123	666	101	554	101	104

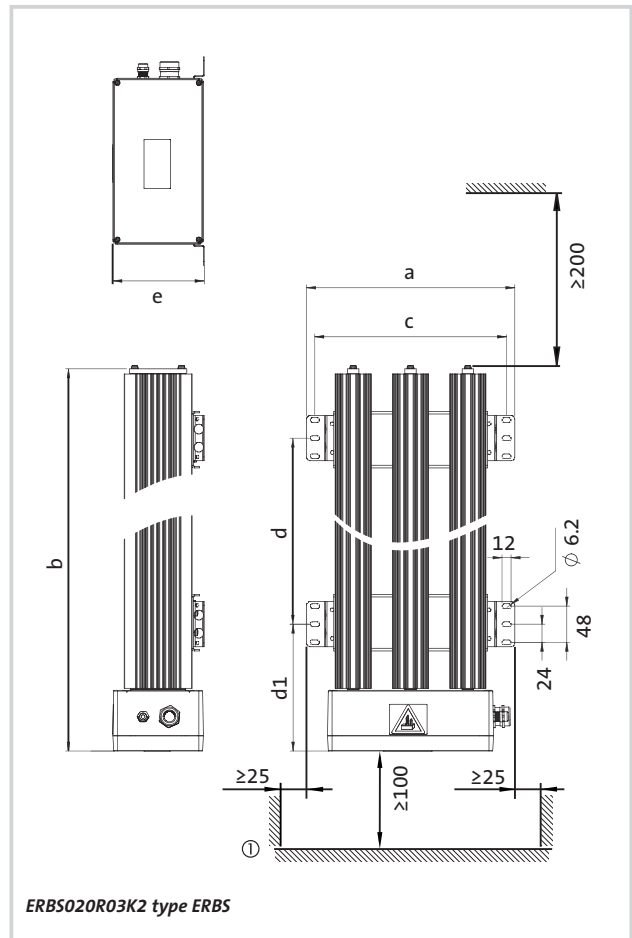
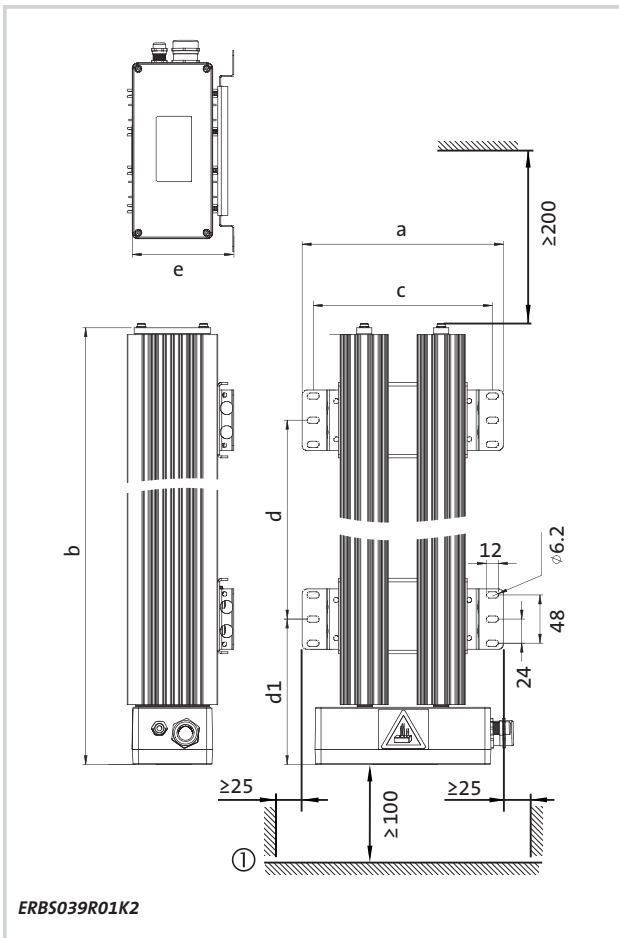

Brake resistor Order number	Dimensions [mm]					
	a	b	c	d	d1	e
ERBS039R01K2	200	747	178	510	145	106
ERBS022R03K2	276	810	254	550	168	121

Brake resistor Order number	Resistance [Ω]	Permanent power [kW]	Peak power [kW]	Thermal capacity [kW·s]	m [kg]
ERBS082R780W	82	0.78	7.8	117	3.7
ERBS039R01K2	39	1.2	16.4	248	8.4
ERBS022R03K2	22	3.2	32.0	485	13.2

The above data requires a maximum OT of 10% with a maximum cycle time of 150 s (15 s braking/ 135 s idling).

System accessories

System cables

It couldn't be easier to connect the Lenze servo motors to the servo controllers thanks to the Lenze system cable concept. A general schematic overview of the extensive range appears below.

As the selection of the required cable type depends primarily on the requirements of the servo motor used, the detailed selection tables for all motor-side cables appear in the Lenze Global Drive servo motors catalogs.

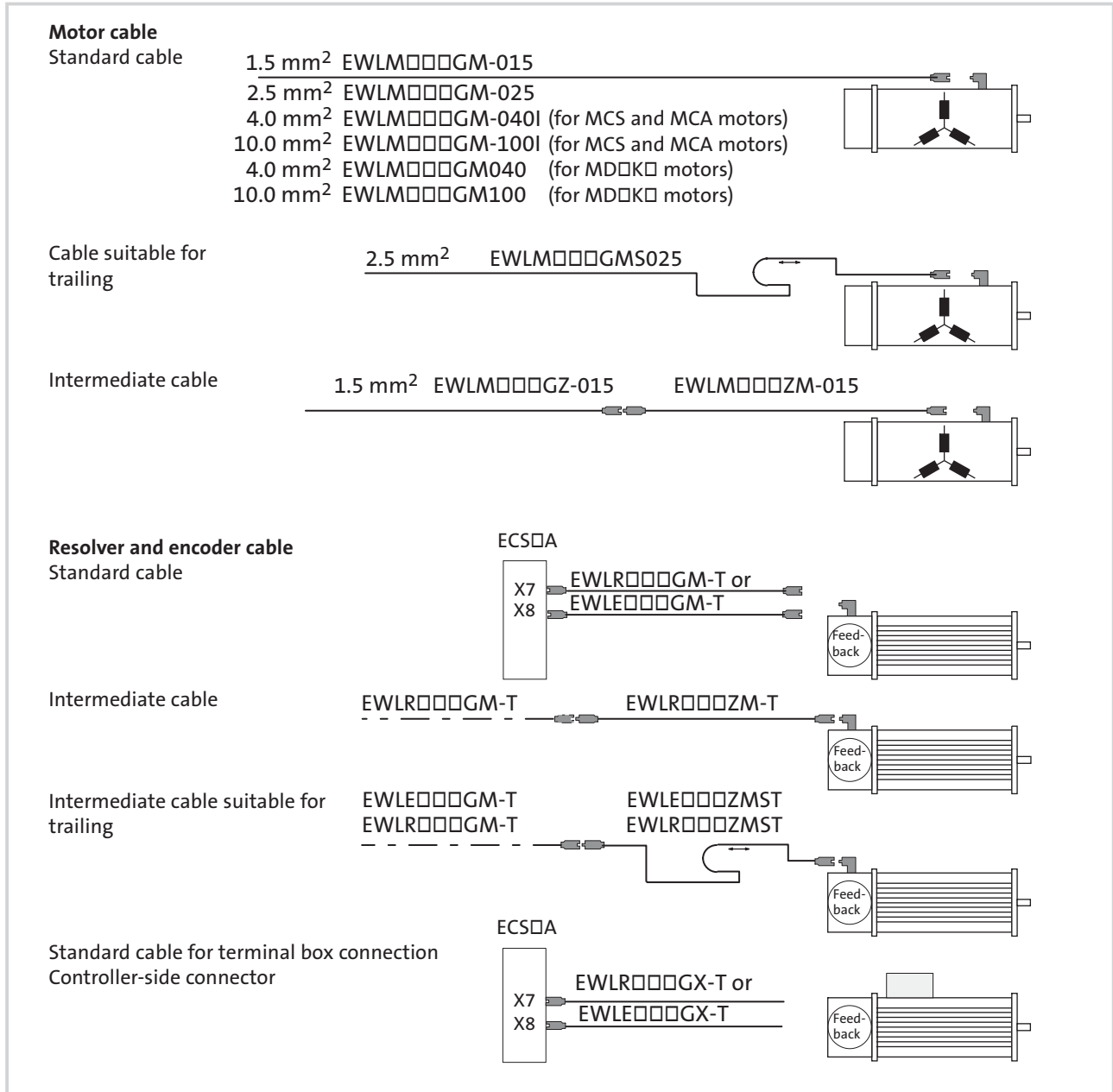

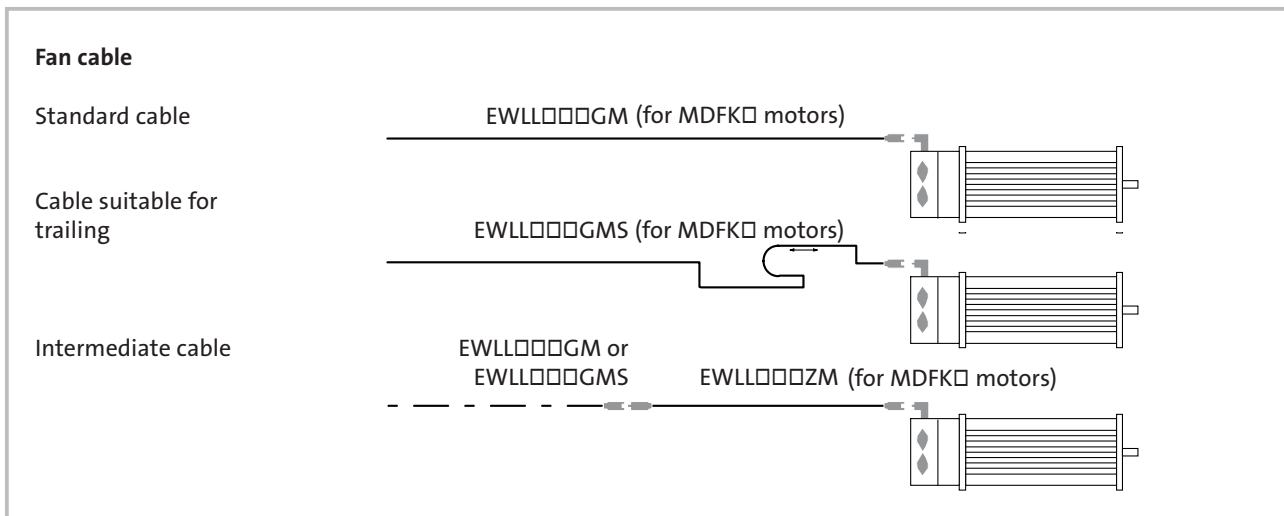

□ Cable length [m]

Master frequency cable

The master frequency input (X8) provides a means via which ECS servo system axis modules can be operated in the master frequency network with other servo controllers.

Order number	Length	Cross-section/ No. of wires	Cable diameter	Bend radius		Weight
	[m]			[mm ²]	Fixed installation	
EWLD002GGBS93	2.5	1x (2x 0.5) + 3x (2x 0.14)	9.3	7.5x d	15x d	0.4

Cable protection fuses

Circuit-breakers or UL-approved fuses are recommended as cable protection. Depending on the mains currents of the supply modules, the following rated currents must be applied on the protective devices:

Supply module	Design to VDE		Design to UL		Note
	Circuit-breaker	Cable cross-section [mm ²]	UL fuse	AWG	
ECS□E012	C16 A	2.5	25 A	10	With UL fuse characteristic K5 or H
ECS□E020	C16 A	2.5	25 A	10	
ECS□E040	C32 A	6	35 A	8	With UL fuse characteristic K5 or H, only 400% rated current permissible

This table is only a recommendation. The requirements of national and regional legislation (VDE, UL, EVU, etc.) must also be taken into account.

Only use UL-approved cables, fuses and fuse holders in UL-approved systems.

System accessories

Connectors

The universal connection concept for all power and control connections on the ECS servo system ensures fast and service-friendly connections between the servo controllers, the connected motors and all control connections. As the system connectors can be ordered separately from the

active system components, this concept enables the user to set up the entire system cabling in advance under optimum conditions before inserting the active components at a later point in time.



Accessories set ECSZA



Accessories set ECSZE

	Order number	Contents
ECSZA accessories set for axis modules ECS□A□□□	ECSZA000XB	Connector set for power and control connections (axis module)
ECSZE accessories set for supply modules ECS□E□□□	ECSZE000XB	Connector set for power and control connections (supply module)
ECSZK accessories set for capacitor modules ECS□K□□□	ECSZK000XB	Connector set for power and control connections (capacitor module)

Lenze ECSZS shield assembly sets ensure the EMC-compliant and safe connection of cable shields for all cables connected to ECS modules. The wide cable shield contact area ensures safe and problem-free operation with minimum noise radiation. The shield assembly set can be used on all ECS axis and supply modules.



Shield assembly set

Shield assembly set for	Order number	Contents
ECS□A and ECS□E	ECSZS000X0B001	Mounting plate and shield terminals for motor, communication and control cables (ECS□A) or mains cable

Operating and configuration software Global Drive Control

Version 4.6

The Global Drive Control (GDC) PC software is an easy-to-use and transparent tool for operating, parameter setting and diagnosing drive tasks with the ECS servo system.

GDC features include:

- ▶ Quick and easy commissioning of the drive by means of the short setup function
- ▶ Easy operation even for inexperienced users thanks to extensive help functions
- ▶ User-friendly diagnostics options via various monitor windows and oscilloscope functions
- ▶ Easy drive connection via RS232/485, optical fibres or via the system bus

Global Drive Control system requirements

In order to be able to use Global Drive Control, the following minimum hardware and software requirements must be met by the PC:

- ▶ Microsoft® Windows® 95/98/Me, Windows NT® 4.0 SP5 or higher or Windows 2000 SP2/XP or higher
- ▶ IBM compatible PC with Intel® Pentium®-90 processor
- ▶ 128 MB RAM
- ▶ 180 MB free hard disk space
- ▶ CD-ROM drive
- ▶ Internet Explorer Version 5 or higher
- ▶ Free slots/interfaces in accordance with the requirements of the fieldbus interface module to be used

We also recommend the use of a mouse.

In software version 4.7 and higher, the Global Drive Control PC software is also available as “GDCEasy” with restricted function level as a free download for the ECS system from Lenze's Internet site.

More detailed information about the “Global Drive Control” configuration software appears in the Lenze “Automation” catalog, ID no 494 445.

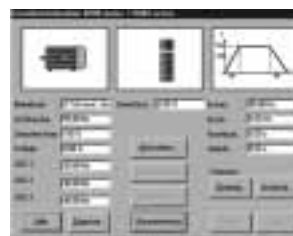
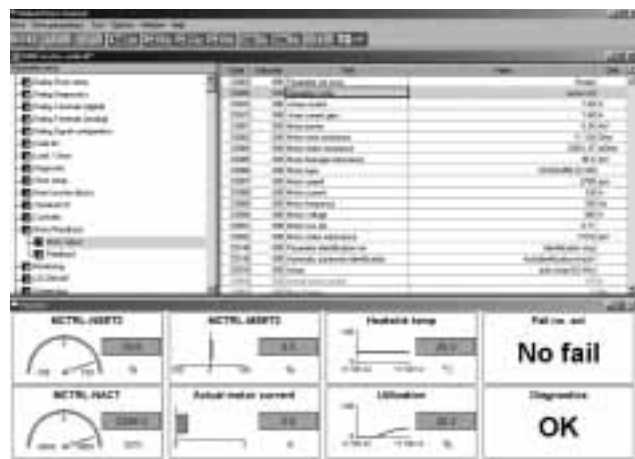
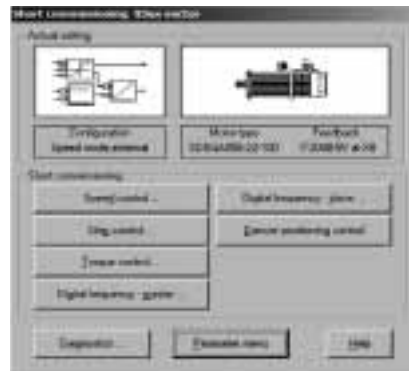

Global Drive oscilloscope (integrated into Global Drive Control)

Version 2.1

The Global Drive oscilloscope (GD oscilloscope) has been developed specifically for the 9300 Servo PLC and the ECS servo system to provide these target systems with a powerful oscilloscope function.

On large systems in particular, it can be difficult to determine speeds or torques on individual drives. However, it is knowledge of precisely these values which can make setting up these machines much easier.

The GD oscilloscope means that it is no longer necessary to connect and install complex measuring instruments – the target systems themselves are the comprehensive measuring instrument for all measured variables affecting the drive.

The advantages for you

- ▶ Precise detection of device-specific process factors with 8 channels
- ▶ No need to temporarily install measuring sensors in the system
- ▶ User-friendly documentation when fine-tuning control loops
- ▶ Easy maintenance and troubleshooting

The GD oscilloscope is characterised by the following features:

- ▶ Recording and storage of measured values in the controller
- ▶ The size of the measured value memory can be configured
- ▶ Measurement of up to eight independent channels at the same time
- ▶ Configurable time per scan for measuring fast and slow signals
- ▶ Trigger on channel, variable
- ▶ Trigger on error message
- ▶ Pre-triggering and post-triggering (detection of pre-trigger and post-trigger history)
- ▶ Graphic display and evaluation of measured values on a PC
- ▶ Cursor and zoom function for analysing measurements
- ▶ Loading and saving of cams
- ▶ Messages can be annotated and printed
- ▶ Overlap function makes it easy to compare measurements
- ▶ Cam data can be transferred to the clipboard for subsequent processing

More detailed information about the Global Drive oscilloscope appears in the Lenze “Automation” catalog, ID no. 494 445.

Global Drive oscilloscope system requirements

In order to be able to use the Global Drive oscilloscope, the following minimum hardware and software requirements must be met by the PC:

- ▶ Microsoft® Windows® 98/Me, Windows NT® 4.0 or Windows 2000/XP
- ▶ IBM compatible PC with Intel® Pentium®-166 processor
- ▶ 64 MB RAM
- ▶ 40 MB free hard disk space
- ▶ CD-ROM drive
- ▶ Mouse

The ECS operating system must be V3.0 or higher.

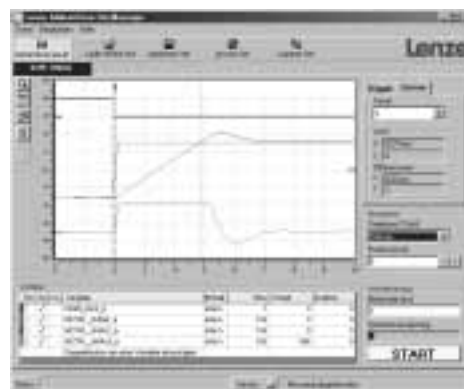

Global Drive Loader

Version 2.1

The Global Drive Loader is the ideal tool for problem-free and secure standard set-up. It couldn't be easier to use, as there is no need for a development environment or parameter settings. Only compiled PLC programs (files from the Drive PLC Developer Studio) and parameter set files (files from Global Drive Control) can be transferred from the PC to the target system. As these files cannot be modified with GD Loader, this prevents data being tampered with by unauthorised users.

The advantages for you

- ▶ Dedicated program for setting up inverters in standard machines
- ▶ Data cannot be tampered with
- ▶ Operation couldn't be easier
- ▶ Automatic batch mode provides a quick and easy way of transferring a variety of files to a number of target systems
- ▶ Free download from the Internet

You can continue to use the following software products to modify and create files:

- ▶ Drive PLC Developer Studio V1.0 or higher
- ▶ Global Drive Control V4.31 or higher

The latest version of GD Loader can be downloaded free of charge from the Downloads area at www.Lenze.com. A GD Loader is also supplied on the CDs for the following software products. Depending on the version, the CDs may not contain the latest version of GD Loader.

- ▶ Drive PLC Developer Studio V2.0 or higher
- ▶ Global Drive Control V4.5 and higher
- ▶ Global Drive Control easy V4.5 or higher



More detailed information about the Global Drive Loader appears in the Lenze "Automation" catalog, ID no. 494 445.

Target systems

GD Loader V2.1 can be used for the following target systems:

- ▶ 8200 vector/8200 motec
- ▶ 9300 Servo PLC
- ▶ Drive PLC
- ▶ Terminal extension
- ▶ ECS servo system

Global Drive Loader system requirements

In order to be able to use the Global Drive Loader, the following minimum hardware and software requirements must be met by the PC:

- ▶ Microsoft® Windows® 98/Me, Windows NT® 4.0 SP5 or higher or Windows 2000 SP2/XP or higher
- ▶ IBM compatible PC with Intel® Pentium®-90 processor
- ▶ 32 MB RAM
- ▶ 15 MB free hard disk space
- ▶ CD-ROM drive for CD version
- ▶ Free slots/interfaces in accordance with the requirements of the fieldbus interface module to be used
- ▶ Mouse

	GD Loader V2.1
Communication via	
System bus (CAN) via USB	with PC system bus adapter (USB) ¹⁾
System bus (CAN) via parallel interface	with PC system bus adapter
Languages	German, English, French
Order no.	Corporate licence can be downloaded free of charge from www.Lenze.com

¹⁾ Not valid for Microsoft Windows NT. This operating system does not support USB.



I/O system to IP20

The ideal solution for every application

The increasing level of automation in machines and systems and the consequent rise in the number of I/O devices have in turn increased the amount of wiring required. Decentralised I/O systems bring order to this chaos. Lenze has developed two product concepts which are suitable for both basic digital applications and more complex automation tasks.

The compact system

The product family comprises a range of compact products with a fixed number of digital inputs and outputs. It has a built-in communication interface in the form of the CAN system bus. The compact system is available in four different versions – one of which is bound to meet your exact application requirements.

8, 16 and 32-channel modules can be supplied in one or three-wire technology with up to 24 inputs and 8 outputs.

The modules have a SUB-D plug for the connection of the system bus, pluggable tension spring terminal strips to speed up the wiring process and a switch for the node address. The compact system offers operational reliability, can be mounted quickly and easily on 35 mm standard mounting rails and is even easy to configure. All in all, this makes for speedy commissioning.



The modular system

We can provide a complete range of I/O systems for more complex automation applications. The modular system comprises three components: a gateway, electronics modules and a backplane bus.

The modular system is connected to the CAN system bus via the gateway. An internal backplane bus is used for the intra-station communication of process and parameter data, as well as diagnostic data.

The electronics modules house the actual I/O functions. Up to 32 units can be combined as required to form an overall station where each module is optimised for the individual application in which it is to be used.

The electronics module range comprises the following products:

- ▶ Digital input – 8 channels
- ▶ Digital output – 8 channels – 1 A, 2 A
- ▶ Digital output – 4 channels – 5 A relay
- ▶ Digital I/O – 8 channels
- ▶ Analog input – 4 channels
- ▶ Analog output – 4 channels
- ▶ Counter – 1 MHz



More detailed information about I/O systems appears in the Lenze "Automation" catalog, ID no. 494 445.

Human machine interfaces

Visualisation made easy

Requirements of today's machines and systems in terms of efficiency and effectiveness are constantly on the increase. User-friendliness and monitoring reliability for complex machines are characteristics which are beginning to dominate. Lenze can provide a wide range of human machine interface products, from text displays to graphics displays and beyond to touch screen units, with just one software program common to all: the HMI Designer.

Select a multiplicity of functions according to device type, e.g.:

- ▶ Display of text, images, bar graphs, bitmaps and animated graphics
- ▶ Recipe management
- ▶ Display of system and alarm messages
- ▶ Windows fonts
- ▶ Automatic operations
- ▶ Communication via Lenze system bus

Touch screens



Text displays

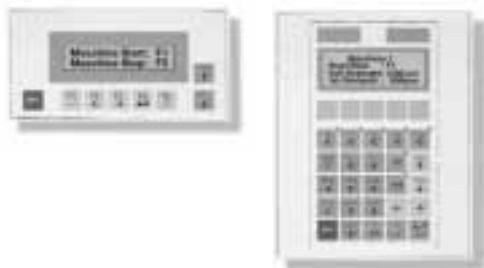

Graphics displays

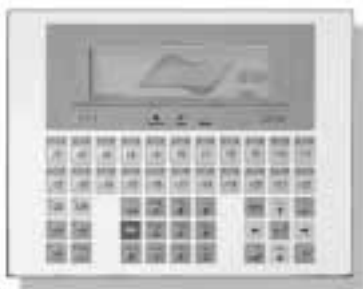

A more detailed description of the Lenze human machine interfaces appears in the "Global Drive Automation" catalog, ID no. 494 445.

Drive PLC

The Drive PLC is ideal for managing central control tasks in a multi-axis servo application. The languages of the international standard IEC 61131-3 are used for programming.

Three different extension boards and two function modules are available to create additional device interfaces.

A true system

- ▶ Straightforward engineering using a special software library for simple integration of Lenze drive technology into the PLC program
- ▶ No need for control cables due to the integrated system bus interface
- ▶ Can be mounted side-by-side with drive modules
- ▶ Slots for extension boards and communication modules

Extension boards

The extension boards are plugged into the side of the Drive PLC.

▶ Extension board 1

For the connection of three-wire sensors and switching outputs for 24 V DC

▶ Extension board 2

For the cost-effective connection of digital sensors and actuators

▶ Extension board 3

For high-speed counting, length measurements and closed-loop control applications

Built-in gateway function

No additional costs for gateway function on higher-level bus systems such as INTERBUS, PROFIBUS or DeviceNet to devices connected to the Drive PLC via the system bus (CAN).

CE conformance

The Drive PLC meets the requirements of the EC's Low Voltage Directive.

UL approval

Approval to UL 508C means that the Drive PLC can be used anywhere in the world.

More detailed information about the Drive PLC appears in the Lenze "Automation" catalog, ID no. 494 445.



System accessories

ETC motion control controller

The ETC motion control controller is available for system-compliant multi-axis co-ordination. This controller, which is an integral component of the Lenze Global Drive system, can be used for the universal automation of your assembly, handling or production machines.



ETCPC

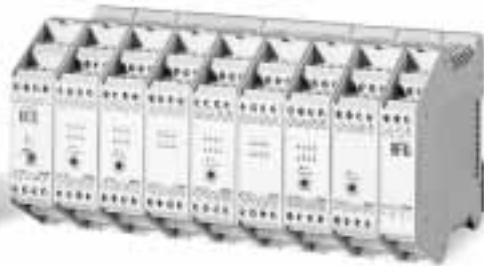

ETC system components



ETCHC

The ETC motion control controller is available in two versions: ETCHC for 4 or 8 axes with problem-free mounting on DIN rails and ETCPC for controlling 4, 8 or 12 axes as a compact pluggable card controller for your PC. Both designs provide the same extensive functions:

- ▶ Standardised bus communication via Ethernet (TCP/IP) and CAN interface
- ▶ Additional, separate motion control bus (CAN) with 1 ms cycle time
- ▶ Powerful motion control operating system with 32-bit controller
- ▶ Extensive and extendable command sets for programming to DIN 66025
- ▶ For the built-in PLC part, free programming in IEC 61131-3 languages
- ▶ Extensive scope of application, from simple positioning tasks to complex 3D path controls
- ▶ Additional pluggable I/O modules for DIN rail mounting

Simple and efficient programming as well as transparent and clear visualisation and operation using the ETCMMI software package with the following functions:

- ▶ Program generation
- ▶ Extensive diagnostics tools
- ▶ Automatic control
- ▶ PLC control via freely programmable buttons
- ▶ Visualisation
- ▶ Operation via keyboard, mouse or touch panel

We would be delighted to advise you on your specific application.



Power recovery is not usually required in the highly dynamic multi-axis applications for which the ECS servo system is primarily used. However, should it be necessary to recover braking energy to the supply system in an application due to specific supplementary conditions, the 9341, 9342 and 9343 regenerative power supply modules from the Global Drive 9300 servo controller range are the ideal solution. Technical data for these devices appears in the Lenze "Servo inverters 9300" catalog (ID no. 454 202). The regenerative power supply modules are available both as built-in units and with thermal separation (push-through technique). Please note that the regenerative power supply modules can only be used as an alternative to the ECS supply modules.

Please contact us should you require dimensioning assistance.



934□ regenerative power supply module

m_1

s, v, a

η_1

d_1

j_1

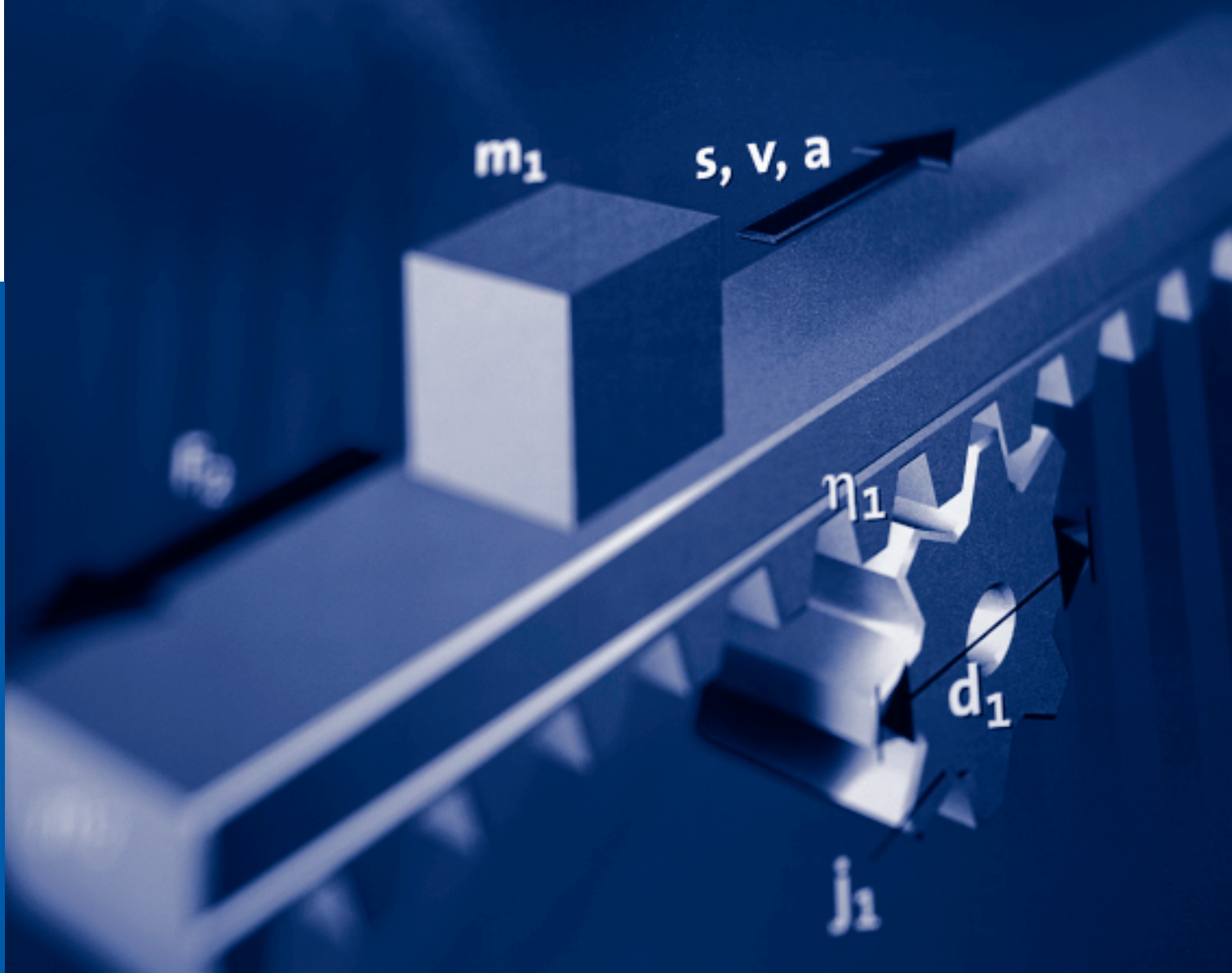

Dimensioning information | ECS servo system

Device connection

Power network _____ 4-2
Connection for control signals _____ 4-3

Power network

A typical wiring diagram for a power network comprising ECS axis and supply modules appears below.

Please select the cable cross-section for the mains cable based on the maximum input current of the supply module (see page 3-15).

A minimum conductor cross-section of 6 mm² should be selected for wiring the DC-bus connection.

A fuse does not need to be provided for the DC-bus connection.

In order to ensure the problem-free and EMC-compliant wiring of the motor cables, please use the Lenze ECSZS shield assembly set for the shield connection (see page 3-17).

Please select the cross-section of the motor connecting cables based on the maximum motor standstill current.

Please dimension the input-side circuit-breaker in accordance with the table on page 3-15.

Power network with external or internal ballast resistor

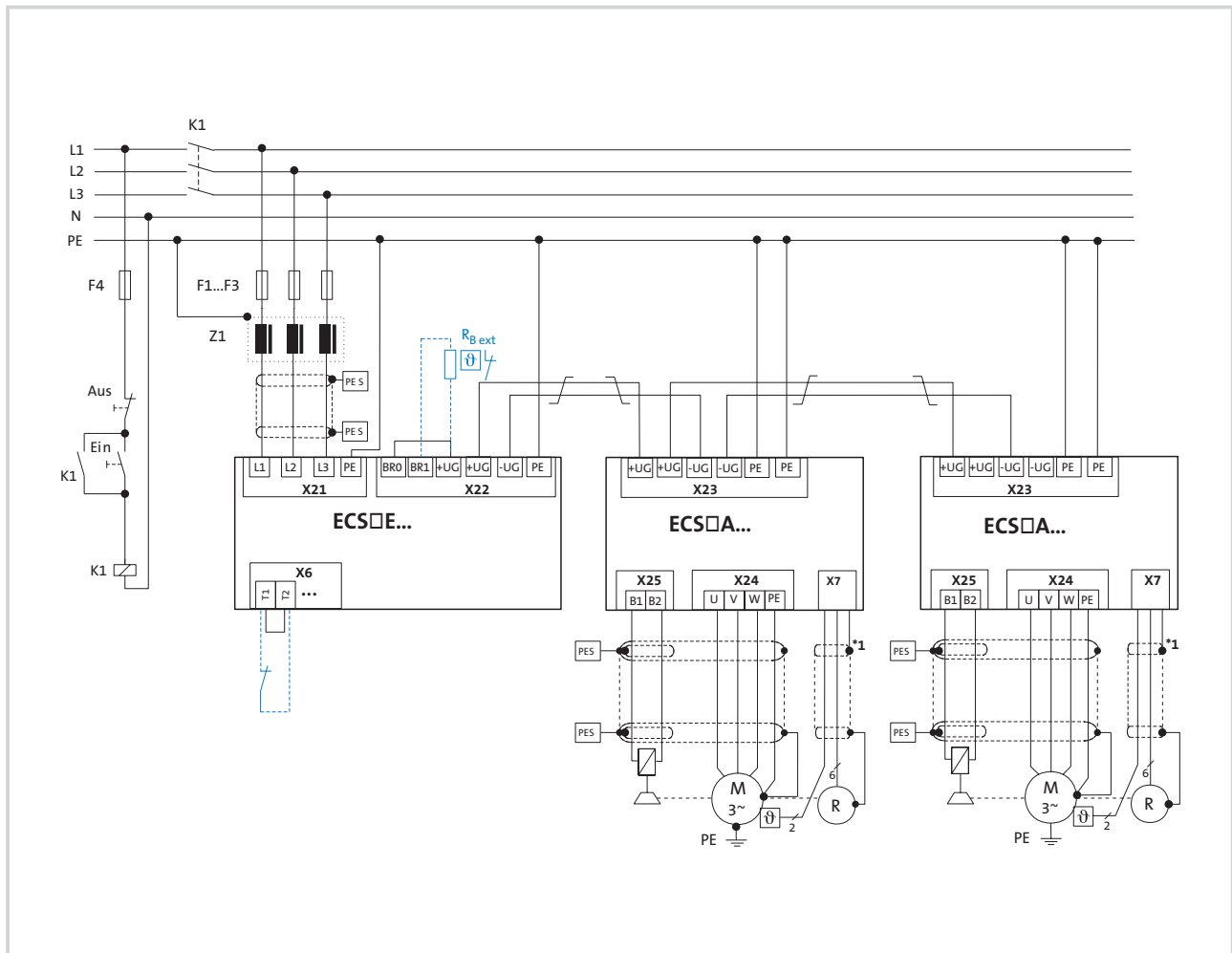

- PES HF shield termination by means of wide contact with PE
- Twisted wires
- *1 System cable feedback system
- Operation with external ballast resistor



Connection for control signals

A typical control cable layout for a power network comprising ECS axis and supply modules appears below.

Please use a minimum conductor cross-section of 0.25 mm² for the control cables.

In order to ensure the problem-free and EMC-compliant wiring of the control cables, please use the Lenze ECSZS shield assembly set for the shield connection (see page 3-17).

An external 24 V DC voltage is required at terminals X6:+24 and X6:GND for the power supply for the control electronics.

If an external brake resistor is not used, terminals X6:T1 and X6:T2 should be bypassed.

Input X6:DI1 is used to enable mains voltage detection on the supply module. X6:DI2 enables the control and initiates the charging of the DC circuit. Once the circuit has charged without errors, a ready for operation signal is set at X6:DO1. X6:D24 is the supply voltage input for X6:DO1.

Example circuit for wiring control signals

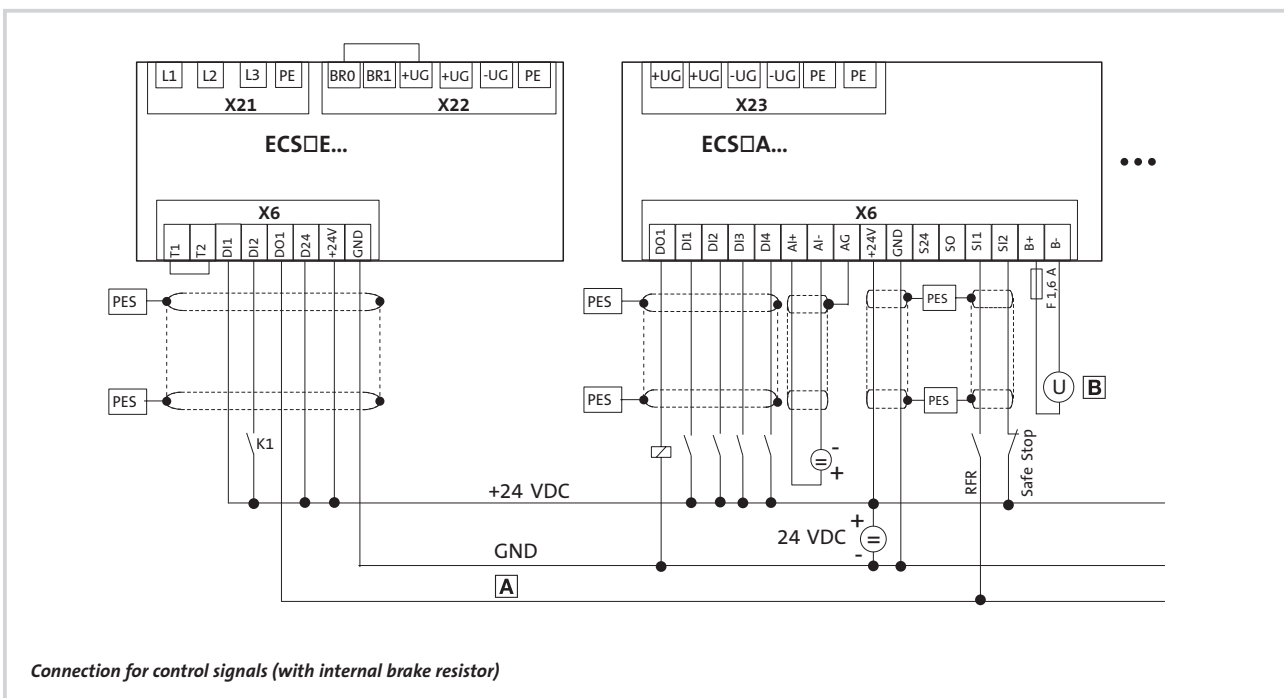

- PES** HF shield termination by means of wide contact with PE
- Twisted wires
- A** Enable axis module
- B** Voltage supply motor holding brake 18 ... 30 V DC, max. 1.5 A

A close-up photograph of a grey plastic component, likely a motor or drive housing, featuring the 'Lenze' brand name embossed in a bold, sans-serif font. The component has a ribbed texture. The image is set against a blue background with a white vertical bar on the left side.

Lenze

Services | ECS servo system

Services
_____ 5-2

**Related
documentation**
_____ 5-3

Fax order form
_____ 5-5

Lenze worldwide
_____ 5-8

For us, service is more than just supporting the use of our drives. The Lenze system approach begins with your enquiry. Next you get technical information and advice from a network of sales outlets staffed by knowledgeable engineers. If you want, we follow up with training, commissioning, maintenance and repair. Our service is always at your disposal.

With passion

The Lenze team does not just offer the necessary manpower and technical know-how – we are passionate and meticulous about what we do. We will only be happy once you are entirely satisfied with our work. Our team of professionals provides assistance over the telephone or on site, ensures the express delivery of spare parts and carries out repairs with incredible urgency. We're fast and reliable.

Someone to talk to

Expert advice is available for all your technical queries via our helpline. In cases of urgent need, call 008000 24 hours (008000 24 46877), Lenze's worldwide expert helpline – 24 hours a day, 365 days a year. For more direct assistance, you can of course contact your local Lenze service support centre. We can tell you where it is – or you can find out for yourself by visiting us on the Internet at www.Lenze.com.

Around the world

Our products are available for speedy delivery worldwide. Lenze companies, Lenze factories and sales agencies are based in major industrial countries around the world. Contact them through our website www.Lenze.com, which also gives you 24-hour access to technical instructions and product manuals. Local support, on site if you need it, is available.





Technical documentation

The technical documentation provides more detailed information about our products:

- ▶ Mounting Instructions in three languages are supplied with our products.
- ▶ Our System Manuals for controllers, our Communication Manuals for bus systems and our Operating Instructions for electromechanical products and accessories provide the information required for planning, designing and developing machines and systems. System Manuals and Communication Manuals are supplied in loose-leaf format. Operating Instructions are bound.
- ▶ Our User's Manuals for our controllers are designed for the operators and users of machines and systems. The information in User's Manuals has been put together so that it can be integrated directly into the machine or system documentation.

All our technical documentation is available free of charge in PDF format

- ▶ Via Internet download from "www.lenze.de", "Downloads" area
- ▶ On the "Lenze Library" CD

System Manuals and Communication Manuals can also be supplied in ring binder format for a nominal fee.

Technical documentation at a glance

Documentation	Contents	Target group	Available languages
Mounting Instructions	Safety instructions, handling and installation	Installation personnel	In three languages: German, English, French
System Manual Communication Manual Operating Instructions	Extensive and comprehensive information for design, construction, development and programming	Planning engineers, design engineers and developers of machines and systems	Single-language version: German, English or French
User's Manual	Safety instructions, handling, troubleshooting and fault elimination	Operators and users of machines and systems	Single-language version German, English or French. Other languages will shortly be available on request



To the Lenze sales office

Page __ of __

- Order
- Quotation

Fax no. _____

From _____
Company _____

Customer no.

--	--	--	--	--	--	--

Street/PO Box _____

Order no. _____

Postcode City _____

Name _____

Department _____

Date Signature _____

Tel. no. _____

Delivery address (if different)

Street _____

Postcode City _____

Invoice to (if different)

Street/PO Box _____

Postcode City _____

Requested delivery date _____

Despatch information _____

Customer no.

--	--	--	--	--	--	--

Page __ of __

Order no.

Axis modules

Number	Design "Built-in"	Number	Design "Push-through technique"	Number	Design "Cold plate"	Price
	ECSEA004		ECSDA004		ECSCA004	
	ECSEA008		ECSDA008		ECSCA008	
	ECSEA016		ECSDA016		ECSCA016	
	ECSEA032		ECSDA032		ECSCA032	
	ECSEA048		ECSDA048		ECSCA048	
	ECSEA064		ECSDA064		ECSCA064	

Supply modules

Number	Design "Built-in"	Number	Design "Push-through technique"	Number	Design "Cold plate"	Price
	ECSEE012		ECSDE012		ECSCCE012	
	ECSEE020		ECSDE020		ECSCCE020	
	ECSEE040		ECSDE040		ECSCCE040	

Capacitor modules

Number	Design "Built-in"	Number	Design "Push-through technique"	Number	Design "Cold plate"	Price
	ECSEK001		ECSDK001		ECSCCK001	
	ECSEK002		ECSDK002		ECSCCK002	

Accessories

Number	Designation	Order number	Price
	Shield assembly set	ECSZS000X0B001	
	Accessories set for axis modules	ECSZA000X0B	
	Accessories set for supply modules	ECSZE000X0B	
	Accessories set for capacitor modules	ECSZK000X0B	

PC system bus adapter

Number	Designation	Order number	Price
	PC system bus adapter, printer port connection	EMF21731B	
	PC system bus adapter, PS2 port connection	EMF21731BV002	
	PC system bus adapter, electrically isolated, PS2 port connection	EMF21731BV003	
	PC system bus adapter, electrically isolated, USB port connection	EMF21771B	



Customer no.

--	--	--	--	--	--	--

Page __ of __

Order no.

Pluggable modules for operation or communication

Number	Designation	Order number	Price
	Operating module	EMZ9371BC	
	LECOM-A/B	EMF2102IBC V001	
	LECOM-B	EMF2102IBC V002	
	LECOM-A	EMF2102IBC V004	
	LECOM-LI	EMF2102IBC V003	
	PROFIBUS-DP	EMF2133IB	
	CANopen/DeviceNet	EMF2175IB	
	LON	EMF2141IB	
	INTERBUS 2000 kB	EMF2113IB	

Mains chokes

Number	Designation	Order number	Price
	for ECS□E012	ELN3-0150H024	
	for ECS□E020	ELN3-0088H035	
	for ECS□E040	ELN3-0055H055	

RFI filter limit class A

Number	Designation	Order number	Price
	for ECS□E012	ECSZZ020X4B	
	for ECS□E020	ECSZZ020X4B	
	for ECS□E040	ECSZZ040X4B	

Brake resistors

Number	Resistance [Ω]	Power [kW]	Type of protection	Order number	Price
	82	0.1	IP50	ERBM082R100W	
	39	0.12	IP50	ERBM039R120W	
	20	0.15	IP50	ERBM020R150W	
	82	0.6	IP20	ERBD082R600W	
	47	1.2	IP20	ERBD047R01K2	
	22	3	IP20	ERBD022R03K0	
	82	0.78	IP65	ERBS082R780W	
	39	1.2	IP65	ERBS039R01k2	
	22	3.2	IP65	ERBS022R03k2	

Lenze AG

Postfach 101352
D-31763 Hameln
Telefon +49 (0)51 54/82-0
Telefax +49 (0)51 54/82-28 00
E-Mail: Lenze@Lenze.de
Internet: www.Lenze.com

Lenze Drive Systems GmbH

Postfach 10 13 52, D-31763 Hameln
Telefon +49 (0)51 54 / 82-0
Telefax +49 (0)51 54 / 82-28 00

Lenze GmbH & Co KG Anlagenbau

Buchenweg 1
D-31855 Aerzen
Telefon +49 (0)51 54 / 82-0
Telefax +49 (0)51 54 / 82-21 00

Lenze Bremsen GmbH

Wülmsers Weg 5
D-31855 Aerzen
Telefon +49 (0)51 54 / 82-14 53
Telefax +49 (0)51 54 / 82-11 04

Lenze GmbH & Co KG Kleinantriebe

Hans-Lenze-Straße 1
D-32699 Extertal
Telefon +49 (0)51 54 / 82-0
Telefax +49 (0)51 54 / 82-14 85

Lenze Service GmbH

Breslauer Straße 3
D-32699 Extertal
Mechanical Drives
Telefon +49 (0)51 54 / 82-16 26
Telefax +49 (0)51 54 / 82-13 96

Electronic Drives

Telefon +49 (0)51 54 / 82-11 11
Telefax +49 (0)51 54 / 82-11 12

Service Helpline

+49 (0)180 5 20 24 26

Lenze Verbindungstechnik GmbH & Co KG

Ipf-Landesstraße 1
A-4481 ASTEN
Phone +43 (0)72 24 / 21 1-0
Telefax +43 (0)72 24 / 21 19 98

Lenze Deto Drive Systems GmbH & Co KG

Gewerbepark Süd 11
A-6330 Kufstein
Telefon +43 (0)53 72 / 6 53 15-200
Telefax +43 (0)53 72 / 6 53 15-299

LS Automation GmbH & Co KG

Jakob-Stadler-Platz 11
D-78467 Konstanz
Telefon +49 (0)75 31 / 9 42 19-0
Telefax +49 (0)75 31 / 9 42 19 20

encoway GmbH & Co KG

Universitätsallee 21-23
D-28359 Bremen
Telefon +49 (0)4 21 / 2 46 77-0
Telefax +49 (0)4 21 / 2 46 77-10

DEUTSCHLAND/GERMANY

Lenze Vertrieb GmbH

Ludwig-Erhard-Straße 52-56
D-72760 Reutlingen
Telefon +49 (0)71 21 / 9 39 39-0
Telefax +49 (0)71 21 / 9 39 39-29

Region Nord
Dornenpark 1
31840 Hessisch Oldendorf
Telefon (0 51 52) 90 36-0
Telefax (0 51 52) 90 36-33/44/55

Region West
Postfach 10 12 20
47497 Neukirchen-Vluyn
Kelvinstraße 7
47506 Neukirchen-Vluyn
Telefon (0 28 45) 95 93-0
Telefax (0 28 45) 95 93 93

Region Mitte/Ost
Postfach 1463
35724 Herborm
Austraße 81
35745 Herborm
Telefon (0 27 72) 95 94-0
Telefax (0 27 72) 5 30 79

Region Südwest
Postfach 14 33
71304 Waiblingen
Schänzle 8
71332 Waiblingen
Telefon (0 71 51) 9 59 81-0
Telefax (0 71 51) 9 59 81 50

Region Süd
Fraunhoferstraße 16
82152 Martinsried
Telefon (0 89) 89 56 14-0
Telefax (0 89) 89 56 14 14

WELTWEIT/WORLDWIDE

ALGERIA

see FRANCE

ARGENTINA *

E.R.H.S.A.
Girardot 1368, 1427 BUENOS AIRES
Phone +54 (0)11 / 45 54 32 32
Telefax +54 (0)11 / 45 52 36 11

AUSTRALIA *

FCR Motion Technology Pty. Ltd.
Unit 6, Automation Place
38-40 Little Boundary Rd.
LAVERTON NORTH, Vic. 3026
Phone +61 (3) 9362 6800
Telefax +61 (3) 9314 3744

AUSTRIA *

Lenze Antriebstechnik GmbH
Ipf-Landesstraße 1
4481 ASTEN
Phone +43 (0)7224 / 21 0-0
Telefax +43 (0)7224 / 21 09 99

Office Dornbirn:
Lustenauer Straße 64
6850 DORNBIERN
Phone +43 (0)5572 / 26 789-0
Telefax +43 (0)5572 / 26 789-66

Office Wr. Neudorf:
Triester Straße 14/109
2351 WR. NEUDORF
Phone +43 (0)2236 / 2 53 33-0
Telefax +43 (0)2236 / 2 53 33-66

Office Graz:
Seering 8
8141 UNTERPREMSTÄTTEN
Phone +43 (0)3135 / 56 900-0
Telefax +43 (0)3135 / 56 900 999

Lenze Verbindungstechnik GmbH & Co KG
Ipf-Landesstraße 1
4481 ASTEN
Phone +43 (0)7224 / 21 1-0
Telefax +43 (0)7224 / 21 19 98
Lenze Anlagentechnik GmbH & Co KG
Mühlenstraße 3
4470 ENNS
Phone +43 (0)7223 / 886-0
Telefax +43 (0)7223 / 886-997

BELGIUM *

Lenze bv.ba
Noorderlaan 133
bus 15
2030 ANTWERPEN
Phone +32 (0)3 / 54 26 20 0
Telefax +32 (0)3 / 54 13 75 4

BOSNIA-HERZEGOVINA

see AUSTRIA

BRAZIL *

AC Control Ltda
Rua Gustavo da Silveira 1199
Vila Sta. Catarina
SÃO PAULO – S.P.
04376-000
Phone (+55) 11 55 64 65 79 ramal: 214
Telefax (+55) 11 56 79 75 10

BULGARIA

see MACEDONIA

CANADA *

see USA

CHILE

Sargent S.A.
Tecnica Thomas C. Sargent
S.A.C.é.l.
Casilla 166-D
SANTIAGO DE CHILE
Phone +56 (0)2 / 51 03 000
Telefax +56 (0)2 / 69 83 989
Aupi Ltda.
Automation y Proceso Industrial
Camino a Melipilla No. 262
Casilla 80
SANTIAGO DE CHILE
Phone +56 (0)2 / 811 45 20
Telefax +56 (0)2 / 811 11 02 / 811 18 04

CHINA *

Lenze Mechatronic Drives (Shanghai)
Co. Ltd., Section B, 50# building,
No.199 North Ri Ying Road,
Waigaoqiao Free Trade Zone
SHANGHAI, 200131
Phone +86-21-5046 0848
Telefax +86-21-5046 0850
Beijing Office
Rm. 401, Huaxin Mansion
No. 33 An Ding Road
Chaoyang District
BEIJING 100029
Phone +86-10-6441 1470
Telefax +86-10-6441 1467

CROATIA

Lenze Antriebstechnik GmbH
Predstavnista Zagreb
Ulica Grada Gospica 3
HR-1000 ZAGREB
Phone +385-1-249 80 56
Telefax +385-1-249 80 57

CZECH REPUBLIC

Lenze, s.r.o.
Central Trade Park D1
396 01 HUMPOLEC
Phone +420 565 507-111
Telefax +420 565 507-399

Büro Červený Kostelec:
17. listopadu 510
549 41 ČERVENÝ KOSTELEČ
Phone +420 491 467-111
Telefax +420 491 467-166

DENMARK *

Lenze A/S
Vallensbækvej 18A
2605 BRØNDBY
Phone +45 / 46 96 66 66
Telefax +45 / 46 96 66 60
24 stunde service +45 / 40 93 04 11
Buero Jylland:
Lenze A/S
Enebærvej 11
8653 THEM
Phone +45 / 46 96 66 66
Telefax +45 / 46 96 66 80

EGYPT

WADI Co. for technologies
and development
P.O.Box 209, new center Ramses
11794 CAIRO, Egypt
11 Syria St., Mohandessin
GIZA, Egypt
Phone +20 (2) 347 6842
Telefax +20 (2) 347 6843

ESTONIA

see FINLAND

FINLAND *

Lenze Drives
Rykmentintie 2 b
20810 TURKU
Phone +358 2 2748 180
Telefax +358 2 2748 189

FRANCE *

Lenze S.A.
Siege
Z.A. de Chanteloup
Rue Albert Einstein
93603 AULNAY-SOUS-BOIS

Services Commerciaux
Tel. 0 825 086 036
Fax 0 825 086 346

Centre de formation
E-Mail:semin.sidonie@lenze.fr

Question générales / Documentation
E-Mail:lenze@lenze.fr

Service Après-vente / assistance en ligne
Helpline 24/24 : 0 825 826 117
E-Mail:helpline@lenze.fr

Agences en France
Région France Nord :
Z.A. de Chanteloup
Rue Albert Einstein
93603 AULNAY-SOUS-BOIS

Lille
59420 MOUVAUX
Strasbourg
67960 ENTZHEIM

Rouen
76500 ELBEUF

Région France Sud :
Rond point du sans souci
69578 LIMONEST Cedex
Toulouse
31400 TOULOUSE
Agen
47270 SAINT-PIERRE DE CLAIRAC

GREECE

George P. Alexandris S.A.
12K. Mavromichali Str.
185 45 PIRAEUS
Phone +30 (0)210 / 41 11 84 15
Telefax +30 (0)210 / 41 11 81 71
4 12 70 58

183 Monastiriou Str.
546 27 THESSALONIKI
Phone +30 (0)310 / 5 56 65 04
Telefax +30 (0)310 / 51 18 15

HUNGARY *

Lenze Antriebstechnik
Handelsgesellschaft mbH
2040 BUDAÖRS
Gyár utca 2., P.O.Box 322.
Phone +36 (0)23 / 501-320
Telefax +36 (0)23 / 501-339

ICELAND

see DENMARK

**INDIA**

Electronic Service:
National Power Systems
10, Saibaba Shopping Centre
Keshav Rao Kadam Marg
Off Lamington Road
MUMBAI 400 008
Phone +91-22-2300 5667, 2301 3712
Telefax +91-22-2300 5668

Mechanical Service:
Emco Lenze Pvt. Ltd.
1st Floor, Sita Mauli
Madanlal Dhingra Road
Panch Pakhadi, Thane (West)
MAHARASHATRA 400 602
Phone +91-22-25405488
+91-22-25452244
Telefax +91-22-25452233

V3 Controls Pvt. Ltd.
1, "Devayani", Next to SBI, Baner ITI Road,
Sanewadi, Aundh,
PUNE 411 007, MS
Phone +91-20-25 88 68 62
Telefax +91-20-25 88 03 50

INDONESIA

P.T. Futurindo Globalsatya
Jl.: Prof. Dr. Latumenten No. 18
Kompleks Perkantoran
Kota Grogol Permai Blok A 35
JAKARTA 11460
Buero 1:
Phone +62 (0)21 / 766 42 34
765 86 23
Telefax +62 (0)21 / 766 44 20
Buero 2:
Phone +62 (0)21 / 567 96 31
567 96 32
Telefax +62 (0)21 / 566 87 50

IRAN

Tavan Rissan Co. Ltd.
P.O.Box. 19395-5177
No. 44, Habibi St.,
South Dastour St.,
Sadr EXP'Way,
TEHRAN 19396
Phone +98 21 / 260 26 55
260 67 66
260 92 99
Telefax +98 21 / 200 28 83

ISRAEL *

Greensphon Engineering Works LTD
P.O.Box 10 108
HAIFA-BAY 26110
Phone +972 (0)4 / 87 21 18 7
Telefax +972 (0)4 / 87 26 23 1

ITALY *

Gerit Trasmissioni S.p.A.
Viale Monza 338
20128 MILANO
Phone +39 02 / 270 98.1
Telefax +39 02 / 270 98 290

JAPAN *

Miki Pulley Co., Ltd.
1-39-7 Komatsubarua, Zama-city
KANAGAWA 228-8577
Phone +81 (0)462 / 58 16 61
Telefax +81 (0)462 / 58 17 04

LATVIA

see LITHUANIA

LITHUANIA

Lenze UAB
Breslaujos g.3
44403 KAUNAS
Phone +370 37 407174
Fax./Tel.+370 37 407175

LUXEMBOURG *

see BELGIUM

MACEDONIA

Lenze Antriebstechnik GmbH
Pretstavništvo Skopje
ul. Nikola Rusinski 3/A/2, 1000 SKOPJE
Phone +389 2 30 90 090
Telefax +389 2 30 90 091

MALAYSIA

D.S.C. Engineering SDN BHD
3A & 3B, Jalan SS21/56B
Damansara Utama
47400, PETALING JAYA, SELANGOR
Phone +60 (0)3 / 77 25 62 43
77 25 62 46
77 28 65 30
Telefax +60 (0)3 / 77 29 50 31

MAURITIUS

Automation & Controls Engineering Ltd
3, Royal Road, Le Hochet, Terre Rouge
MAURITIUS
Phone +230 248 8211
Telefax +230 248 8968

MEXICO

Automatización y Control
de Energía S.A. de C.V.
Av. 2 No. 89 Esq Calle 13
Col. San Pedro de los Pinos
C.P. 03800 MEXICO D.F.
Phone +52 (55)5277/5998
Telefax +52 (55)5277/5937

MOROCCO

GUORFET G.T.D.R
Automatisation Industrielle
Bd Chefchaouni Route 110 km, 11.500
No. 353-Ain-Sabaâ
CASABLANCA
Phone +212/22-35 70 78
Telefax +212/22-35 71 04

NETHERLANDS *

Lenze B.V., Postbus 31 01
5203 DC'S-HERTOGENBOSCH
Ploegweg 15
5232 BR 'S-HERTOGENBOSCH
Phone +31 (0)73 / 64 56 50 0
Telefax +31 (0)73 / 64 56 51 0

NEW ZEALAND *

Tranz Corporation
343 Church Street
P.O. Box 12-320, Penrose
AUCKLAND
Phone +64 (0)9 / 63 45 51 1
Telefax +64 (0)9 / 63 45 51 8

NORWAY *

Dtc- Lenze as
Stallbakken 5, 2005 RAEILINGEN
Phone +47 / 64 80 25 10
Telefax +47 / 64 80 25 11

PHILIPPINES

Jupp & Company Inc.
Unit 224 Cityland Pioneer Bldg.,
Pioneer Sreet, MANDALUYONG CITY
Phone +63 2 / 687 7423
683 0042
683 0047
Telefax +63 2 / 687 7421

POLAND

Lenze-Rotiw Sp. z o.o.
ul. Rożdżeńskiego 188b
40-203 KATOWICE
Phone +48 (0)32 / 2 03 97 73
Telefax +48 (0)32 / 7 81 01 80
Lenze Systemy Automatyki Sp. z o.o.
Ul. Rydygiera 47
87-100 TORUŃ
Phone +48 (0)56 / 6 58 28 00
6 45 34 60
6 45 35 70
Telefax +48 (0)56 / 6 45 33 56

PORTUGAL *

Costa Leal el Victor
Electronica-Pneumatica, Lda.
Rua Prof. Augusto Lessa, 269,
Apart. 52053
4202-801 PORTO
Phone +351-22 / 5 50 85 20
Telefax +351-22 / 5 02 40 05

ROMANIA

see AUSTRIA

RUSSIA

Inteldrive
1 Buhvostova Street 12/11
Korpus 18 Office 322
MOSCOW 107258
Phone +7 (0)095 / 963 96 86
Telefax +7 (0)095 / 962 67 94

SERBIA-MONTENEGRO

see MACEDONIA

SINGAPORE *

see MALAYSIA

SLOVAC REPUBLIC

ECS Sluzby spol. s.r.o.
Staromlynska 29
82106 BRATISLAVA
Phone +421 2 45 25 96 06
+421 2 45 64 31 47
+421 2 45 64 31 48
Telefax +421 2 45 25 96 06

SLOVENIA

Lenze pogonska tehnika GmbH
Zbiljska Cesta 4
1215 MEDVODE
Phone +386 (0)1 361 61 41
Telefax +386 (0)1 361 22 88

SOUTH AFRICA *

S.A. Power Services (Pty.) Ltd.
P.O. Box 11 37
RANDBURG 2125
Phone +27 (0)11 / 78 71 80 1
Telefax +27 (0)11 / 78 75 04 0

SOUTH KOREA *

Hankuk Mechatro Ltd.
Room# 1409
Samhwan officetel 830-295
Beomil-dong, Dong-Gu
PUSAN
Phone +82 (0)51-635-6663
Telefax +82 (0)51-635-6632

SPAIN *

Lenze Transmisiones, S.A.
Mila i Fontanals, 135-139
08205 SABADELL (Barcelona)
Phone +34 93 / 72 07 68 0
Telefax +34 93 / 71 22 54 1

SWEDEN *

Lenze Transmitter AB
P.O.Box 10 74, Attorpsgatan, Tornby Ind.
58110 LINKÖPING
Phone +46 (0)13 / 35 58 00
Telefax +46 (0)13 / 10 36 23

SWITZERLAND *

Lenze Bachofen AG
Ackerstrasse 45
8610 USTER
Phone +41 (0) 43 399 14 14
Telefax +41 (0) 43 399 14 24
Vente Suisse Romande:
Route de Prilly 25
1023 CRISSIER
Phone +41 (0)21 / 63 72 19 0
Telefax +41 (0)21 / 63 72 19 9

SYRIA

Zahabi Co.
8/5 Shouhadadaa Street
P.O.Box 8262
ALEPPO-SYRIA
Phone +963 21 21 22 23 5
Telefax +963 21 21 22 23 7

TAIWAN *

ACE Pillar Co. Ltd.
No.12, Lane 61, Sec. 1,
Kuanfu Road
San-Chung City
TAIPEI HSIEN
Phone +886 (0)2 / 299 58 40 0
Telefax +886 (0)2 / 299 53 46 6

THAILAND

PackSys Global (Thailand) Ltd.
429 Moo 7, Theparak Road,
Tambol Theparak
Amphur Muang
SAMUTPRAKARN 10270
Phone +66 2 383 5633
Telefax +66 2 383 5637

TUNESIA

see FRANCE

TURKEY

LSE Elektrik
Elektronik Makina
Otomasyon Mühendislik
San. Ve Tic. Ltd. Şti.
Atatürk mah. Cumhuriyet cad.
Yurt sok. No:7
ÜMRANIYE/İSTANBUL
Phone +90 (0)216 / 316 5138 pbx
Telefax +90 (0)216 / 443 4277
Bursa Address:
Demirtaspa Mh.
Ata Sk. Petek Bozkaya Is Merkezi
D Blok No :5 / A
OSMANGAZI / BURSA
Phone +90 (0)224-2733232 pbx
+90 (0)224-2734151
+90 (0)224-2733238
Telefax +90 (0)224-2734150

UKRAINE

SV Altera
Pobedy Av. 44, KIYV
Phone +380-44-2416777
Telefax +380-44-2419084

UNITED KINGDOM/EIRE *

Lenze Ltd.
Caxton Road
BEDFORD MK 41 OHT
Phone +44 (0)1234 / 32 13 21
Telefax +44 (0)1234 / 26 18 15

USA *

AC Technology Corp.
660 Douglas Street
UXBRIDGE, MA 01569
Phone +1 508 / 278-9100
Telefax +1 508 / 278-7873

AC Technology Corp.
1730 East Logan Avenue
EMPORIA, KS 66 801
Phone +1 620 / 343-8401
+1 888 / 269-2381
Telefax +1 620 / 342-2595
+1 800 / 469-0931

AC Technology Corp.
1 W. Illinois Street, Suite 240
ST. CHARLES, IL 60174
Phone +1 630 / 377-7534
Telefax +1 630 / 377-9623



* Countries connected to the free expert helpline 008000 24 hours (008000 24 46877)

Service | you can trust

For us, service is more than just supporting the use of our drives. The Lenze system approach begins with your enquiry. Next you get technical information and advice from a network of sales outlets staffed by knowledgeable engineers. If you want, we follow up with training, commissioning, maintenance and repair. Our service is always at your disposal.

With passion

The Lenze team does not just offer the necessary manpower and technical know-how – we are passionate and meticulous about what we do. We will only be happy once you are entirely satisfied with our work. Our team of professionals provides assistance over the telephone or on site, ensures the express delivery of spare parts and carries out repairs with incredible urgency. We're fast and reliable.

Someone to talk to

Expert advice is available for all your technical queries via our helpline. In cases of urgent need, call 008000 24 hours (008000 24 46877), Lenze's worldwide expert helpline – 24 hours a day, 365 days a year. For more direct assistance, you can of course contact your local Lenze service support centre. We can tell you where it is – or you can find out for yourself by visiting us on the Internet at www.Lenze.com.

Around the world

Our products are available for speedy delivery worldwide. Lenze companies, Lenze factories and sales agencies are based in major industrial countries around the world. Contact them through our website www.Lenze.com, which also gives you 24-hour access to technical instructions and product manuals. Local support, on site if you need it, is available.

Worldwide

Algeria
Argentina
Australia
Austria
Belgium
Bosnia-Herzegovina
Brazil
Bulgaria
Canada
Chile
China
Croatia
Czech Republic
Denmark
Egypt
Estonia
Finland
France

Germany
Greece
Hungary
Iceland
India
Indonesia
Iran
Israel
Italy
Japan
Latvia
Lithuania
Luxembourg
Macedonia
Malaysia
Mauritius
Mexico
Morocco
Netherlands

New Zealand
Norway
Philippines
Poland
Portugal
Romania
Russia
Serbia-Montenegro
Singapore
Slovak Republic
Slovenia
South Africa

South Korea
Spain
Sweden
Switzerland
Syria
Taiwan
Thailand
Tunisia
Turkey
Ukraine
United Kingdom/Eire
USA

www.Lenze.com

